

**Istruzioni per l'uso e l'installazione**

Cappa

**Instructions for use and installation**

Cooker Hood

**Mode d'emploi et installation**

Hotte de Cuisine

**Bedienungsanleitung und Einrichtung**

Dunstabzugshaube

**Kullanım ve montaj talimatları**

Davlumbaz

FTU 3807 W XS – IN2

Instructions Manual

INDEX

RECOMMENDATIONS AND SUGGESTIONS	17
CHARACTERISTICS	18
INSTALLATION	19
USE	23
MAINTENANCE	24

RECOMMENDATIONS AND SUGGESTIONS

INSTALLATION

- The manufacturer will not be held liable for any damages resulting from incorrect or improper installation.
- The minimum safety distance between the cooker top and the extractor hood is 550 mm.
- Check that the mains voltage corresponds to that indicated on the rating plate fixed to the inside of the hood.
- For Class I appliances, check that the domestic power supply guarantees adequate earthing. Connect the extractor to the exhaust flue through a pipe of minimum diameter 120 mm. The route of the flue must be as short as possible.
- Do not connect the extractor hood to exhaust ducts carrying combustion fumes (boilers, fireplaces, etc.).
- If the extractor is used in conjunction with non-electrical appliances (e.g. gas burning appliances), a sufficient degree of aeration must be guaranteed in the room in order to prevent the backflow of exhaust gas. The kitchen must have an opening communicating directly with the open air in order to guarantee the entry of clean air.

USE

- The extractor hood has been designed exclusively for domestic use to eliminate kitchen smells.
- Never use the hood for purposes other than for which it has been designed.
- Never leave high naked flames under the hood when it is in operation.
- Adjust the flame intensity to direct it onto the bottom of the pan only, making sure that it does not engulf the sides.
- Deep fat fryers must be continuously monitored during use: overheated oil can burst into flames.
- The hood should not be used by children or persons not instructed in its correct use.

MAINTENANCE

- Switch off or unplug the appliance from the mains supply before carrying out any maintenance work.
- Clean and/or replace the Filters after the specified time period.
- Clean the hood using a damp cloth and a neutral liquid detergent.

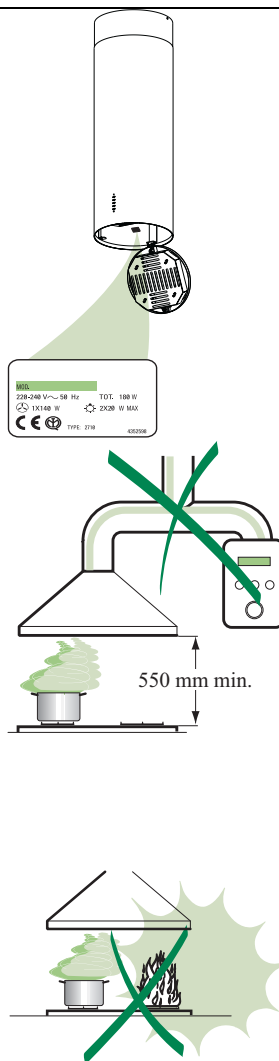

CHARACTERISTICS

Dimensions

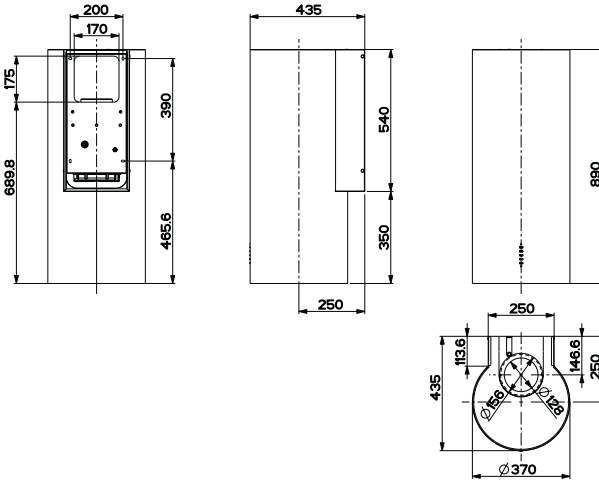

Components

Ref.	Q.ty	Product components
1	1	Hood equipped with: Controls, Lights, Filters
3	1	Hood support equipped with the Exhaust Group
7	1	tube in PVC
8	1	Directioned grid
8c	1	Air outlet reduction $\varnothing 120$ mm
9	1	Reduction flange $\varnothing 150$ -120 mm

Ref.	Q.ty	Installation components
11	4	Small blocks $\varnothing 10$
12a	4	Screws 5 x 70
12b	4	Screws M4 x 15
12e	2	Screws 2,9 x 9,5
13	4	Screws plug M4

Q.ty	Documentations
1	Instruction booklet

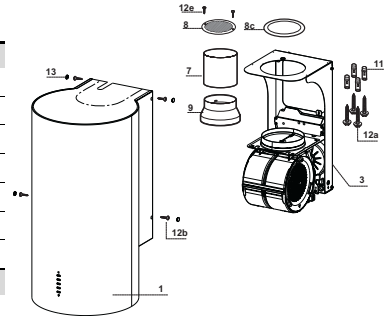

INSTALLATION

Wall drilling and bracket fixing

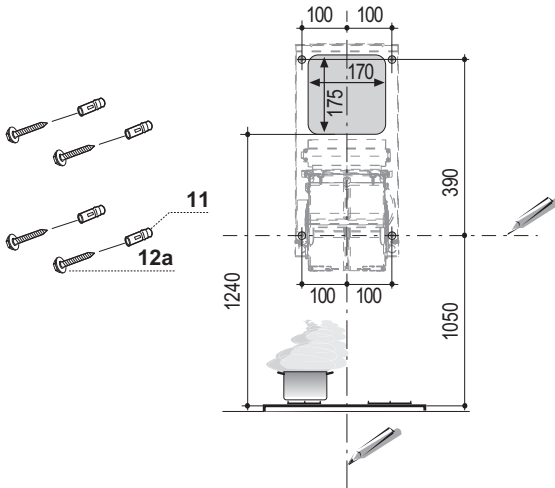

When installing the hood in recycling version it has to be taken into consideration that space remaining between the hood and the upper limit (ceiling or self) is at least 8-10 cm.

On the wall, draw:

- a Vertical line up to the ceiling or upper limit, at the centre of the area in which the hood is to be fitted;
- a Horizontal line at a minimum of 1050 mm above the Cooker Top; .
- As indicated, mark a reference point at 100 mm to the right of the vertical reference line.
- Repeat this operation on the other side, checking that the two marks are level.
- As indicated, mark a reference point at 390 mm above the horizontal reference line, and at 100 mm to the right of the vertical reference line.
- Repeat this operation on the other side, checking that the two marks are level.
- Drill at the points marked, using a \varnothing 10 mm drill bit.
- Insert the plugs **11** into the holes.

Hood support mounting

- Lean the hood support 3 against the wall making sure that holes in the hood support correspond to those in the wall.
- Block the hood support to the wall using 4 **12a** (5 x 70) screws supplied with the hood.
- Before fastening the screws definitively make sure that the support is well-levelled. Only after this operation proceed with the definitive tightening of the screws.

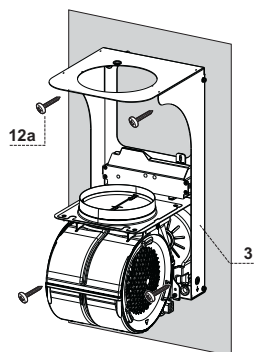

Air outlet connection in the ducting version

When installing the hood in ducting version, basing on the installer's choice, a rigid or a flexible pipe with a \varnothing 150 or 120 mm is used in order to connect the hood to the air outlet piping. The pipe connection can be made on the upper part or on the back side of the hood.

AIR OUTLET ON THE BACK SIDE OF THE HOOD

- When drilling the air outlet hole in the wall proceed in accordance with the scheme in the paragraph concerning the wall drilling.
- In case the connection is made with a \varnothing 120 mm pipe insert the reduction flange 9 on the hood body outlet.
- Fix the pipe with an adequate quantity of pipe clamps. This material is not supplied together with the hood.
- Remove the charcoal filter if present.

AIR OUTLET ON THE UPPER PART OF THE HOOD

- In case the connection of the hood to the air outlet piping is made with a \varnothing 150 mm pipe then use a rigid or a flexible pipe.
- In case the connection is made with a \varnothing 120 mm pipe insert the reduction flange 9 on the hood body outlet.
- Fix the air outlet reduction **8c** to the air outlet hole of the hood support with the screws supplied together with the hood.
- Connect the hood to the piping with a rigid or a flexible pipe.
- Fix the pipe with an adequate quantity of pipe clamps. This material is not supplied together with the hood.
- Remove the charcoal filter if present.

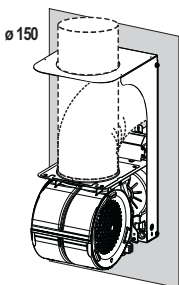
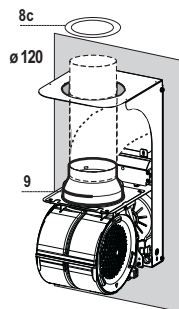

RECIRCULATION VERSION AIR OUTLET

- Insert pvc pipe 7 provided onto the Hood Canopy Outlet.

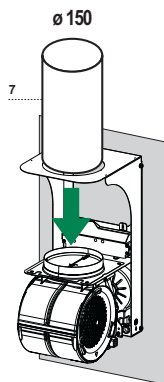

Hood body mounting

Ducting version

- In case the air outlet connection on the upper part of the hood has been chosen it will be necessary to remove the pre-cut piece.
- Lean the hood body on the support and fix it laterally with the 4 **12b** screws.
- Cover the screw seats with the plugs **13** supplied with the hood.

Recycling version

- Remove the pre-cut piece.
- Lean the hood body on the support and fix it laterally with the 4 **12b** screws.
- Cover the screw seats with the plugs **13** supplied with the hood.
- Place the directioned grid **8** on the pipe and make sure that it is correctly installed.
- Fix the directioned grid **8** with the screws **12e** supplied together with the hood.
- Make sure that the charcoal filters are present.

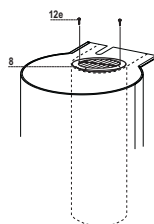
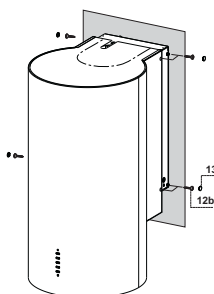
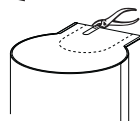

ELECTRICAL CONNECTION

- Connect the hood to the mains through a twopole switch having a contact gap of at least 3 mm.
- Open the lighting unit by pulling on the notch.
- Remove the filters one at a time by pushing them towards the back of the group and pulling down at the same time.
- Being sure that the connector of the feeding cable is correctly inserted in the socket placed on the side of the fan.
- Connect the control connector **Cmd**.
- Connect the Spotlights connector **Lux** to the socket provided behind the lighting unit cover.
- Replace the filters, make sure that the handle is visible on the outside, and the lighting unit.

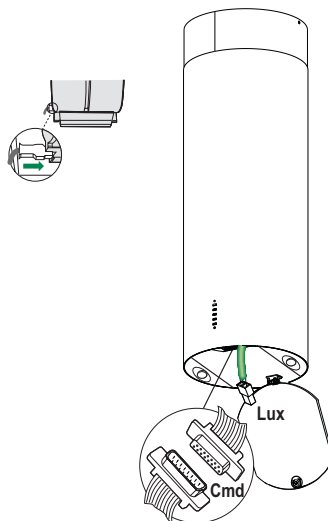

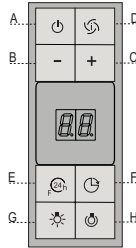

Control board

Key	Function	Display
A	Switches the extractor motor on and off at the latest selected speed	Indicates the selected speed.
B	Decreases the suction speed.	
C	Increases the suction speed.	
D	By pressing this key it is possible to activate the intensive speed from any previously selected speed. The intensive speed can be activated even when the motor is OFF. This speed has been timed at 10 minutes. After that time the system activates automatically the latest selected speed. This function is suitable for cooking conditions when vapours and smells are of the utmost emission.	HI appears. The spot down on the right side flashes once a second.
E	By pressing this key it is possible to set up the motor to a suction speed at 100 m ³ /h lasting 10 minutes every hour. After this the motor switches off automatically. When the filter saturation is going on it is possible to reset the alarm by pressing this key for about 3 seconds. The indication is visible only when the motor is off.	Indicates the 24-function . The spot down on the right side flashes and the motor is on. Once the process is finished the previous indication disappears: FF Indicates that the metal grease filters saturation alarm has been triggered, and the filters need to be washed. The alarm is triggered after 100 working hours. EF Indicates that the charcoal filter saturation alarm has been triggered, and the filter has to be replaced; the metal grease filters must also be washed. The charcoal filter is triggered after 200 working hours.
F	By pressing this key it is possible to set the delayed shutdown of the appliance to 30 minutes. This function is suitable for a complete elimination of the residual smells. It can be activated at any position, and it is deactivated by pressing the key again or by switching off the motor.	Indicates alternately the selected speed of the hood and the time left before the hood shutdown. The spot down on the right side flashes.
G	Turns light on and off .	
H	Turns light on and off at reduced intensity.	

MAINTENANCE

REMOTE CONTROL (OPTIONAL)

The appliance can be controlled using a remote control powered by a 1.5 V carbon-zinc alkaline batteries of the standard LR03-AAA type.

- Do not place the remote control near to heat sources.
- Used batteries must be disposed of in the proper manner.

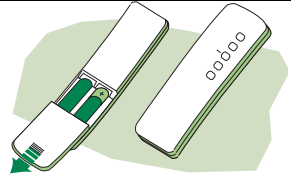

Cleaning the Comfort Panels

- Pull the Comfort Panel to open it.
- Disconnect the panel from the hood canopy by sliding the fixing pin lever.
- The comfort panel must never be washed in a dishwasher.
- Clean the outside using a damp cloth and neutral liquid detergent.
- Clean the inside as well using a damp cloth and neutral detergent; do not use wet cloths or sponges, or jets of water; do not use abrasive substances.
- When the above operation has been completed, hook the panel back to the hood canopy and close it by turning the knob in the opposite direction.

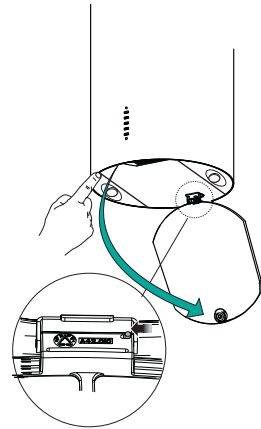

Metal grease filters

Filters can be washed in the dish machine. They need to be washed when **FF**-sign appears on the display or in any case every 2 months, or even more frequently in case of particularly intensive use of the hood.

Alarm reset

- Switch off the hood and the lights. If the 24h-function has been activated this has to be deactivated.
- Press the **E**-key till the display is unlit.

Cleaning the filters

- Pull the comfort panels to open them.
- Remove the filters one by one pushing them towards the back side of the hood unit and simultaneously pulling downwards.
- Any kind of bending of the filters has to be avoided when washing them. Before fitting them again into the hood make sure that they are completely dry. (The colour of the filter surface may change throughout the time but this has no influence to the filter efficiency).
- When fitting the filters into the hood pay attention that they are mounted in correct position the handle facing outwards.
- Close the comfort panel.

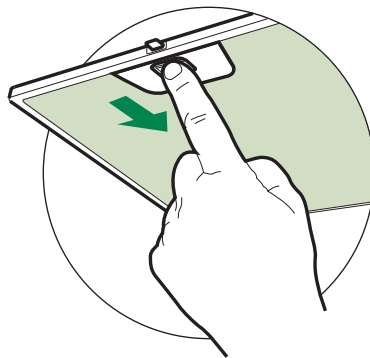

Charcoal filter (recycling version)

- This filter cannot be washed or regenerated. It must be replaced when the **EF** appears on the display or at least once every 4 months.

Activation of the alarm signal

- In the recycling version hoods the filter saturation alarm must be activated during the installation or later.
- Switch off the hood and the lights.
- Disconnect the hood from the mains supply.
- When restoring the connection press and hold **B**-key.
- When releasing the key two rotating rectangles appear on the display.
- **Within 3 seconds** press the **B**-key until a flashing confirmation appears on the display:
 - 2 flashes with **EF** - charcoal filter saturation alarm **ACTIVATED**
 - 1 flash with **EF** - charcoal filter saturation alarm **DEACTIVATED**.

REPLACING THE CHARCOAL FILTER

Reset of the alarm signal

- Switch off the hood and the lighting. If the 24h-function has been activated this has to be deactivated.
- Press the E-key until the display is unlit.

Replacing of the filter

- Open the comfort panels pulling them downwards.
- Remove the metal grease filters.
- Remove the saturated charcoal filter by releasing the fixing hooks
- Fit the new filter and fasten it in its correct position.
- Put the metal grease filters in their seats.
- Close the comfort panels.

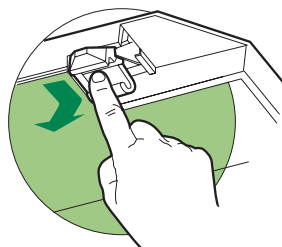

Lighting

LIGHT REPLACEMENT

20 W halogen light.

- Remove the 2 screws fixing the Lighting support, and pull it out of from the Hood.
- Extract the lamp from the Support.
- Replace with another of the same type, making sure that the two pins are properly inserted in the lamp holder socket holes.
- Replace the Support, fixing it in place with the two screws removed as above.

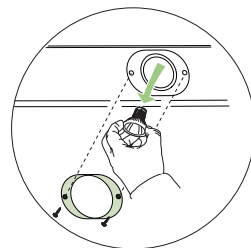



Il simbolo  sul prodotto o sulla confezione indica che il prodotto non deve essere considerato come un normale rifiuto domestico, ma deve essere portato nel punto di raccolta appropriato per il riciclaggio di apparecchiature elettriche ed elettroniche. Provvedendo a smaltire questo prodotto in modo appropriato, si contribuisce a evitare potenziali conseguenze negative per l'ambiente e per la salute, che potrebbero derivare da uno smaltimento inadeguato del prodotto. Per informazioni più dettagliate sul riciclaggio di questo prodotto, contattare l'ufficio comunale, il servizio locale di smaltimento rifiuti o il negozio in cui è stato acquistato il prodotto.



The symbol  on the product or on its packaging indicates that this product may not be treated as household waste. Instead it shall be handed over to the applicable collection point for the recycling of electrical and electronic equipment. By ensuring this product is disposed of correctly, you will help prevent potential negative consequences for the environment and human health, which could otherwise be caused by inappropriate waste handling of this product. For more detailed information about recycling of this product, please contact your local city office, your household waste disposal service or the shop where you purchased the product.



Le symbole  sur le produit ou son emballage indique que ce produit ne peut être traité comme déchet ménager. Il doit plutôt être remis au point de ramassage concerné, se chargeant du recyclage du matériel électrique et électronique. En vous assurant que ce produit est éliminé correctement, vous favorisez la prévention des conséquences négatives pour l'environnement et la santé humaine qui, sinon, seraient le résultat d'un traitement inapproprié des déchets de ce produit. Pour obtenir plus de détails sur le recyclage de ce produit, veuillez prendre contact avec le bureau municipal de votre région, votre service d'élimination des déchets ménagers ou le magasin où vous avez acheté le produit.



Das Symbol  auf dem Produkt oder seiner Verpackung weist darauf hin, dass dieses Produkt nicht als normaler Haushaltsabfall zu behandeln ist, sondern an einem Sammelpunkt für das Recycling von elektrischen und elektronischen Geräten abgegeben werden muss. Durch Ihren Beitrag zum korrekten Entsorgen dieses Produkts schützen Sie die Umwelt und die Gesundheit Ihrer Mitmenschen. Umwelt und Gesundheit werden durch falsches Entsorgen gefährdet. Weitere Informationen über das Recycling dieses Produkts erhalten Sie von Ihrem Rathaus, Ihrer Müllabfuhr oder dem Geschäft, in dem Sie das Produkt gekauft haben.



Ürün veya paketi üzerindeki  sembolü, bu ürünün normal bir evsel atık olarak görülmemesi ve bu tip elektrikli veya elektronik cihazların atıldığı dönüşümlü toplama noktalarına terkedilmesi gerektiğine işaret eder. Bu ürünü gerektiği gibi elimine etme kurallarına uyarız çevre ve insan sağlığı üzerindeki olumsuz etkilerini bertaraf etmeye katkı sağlamış olursunuz. Bu ürünün geri dönüşüm koşulları hakkında daha ayrıntılı bilgi için hudutları içinde bulunduğunuz belediyenin ilgili diariesine, atık yoketme servisine veya ürünün satıcısına danışınız.

Franke S.p.a.
Via Pignolini,2
37019 Peschiera del Garda (VR)
www.franke.it