

# RECOMMENDATIONS AND SUGGESTIONS

---

## INSTALLATION

- The manufacturer will not be held liable for any damages resulting from incorrect or improper installation.
- Check that the mains voltage corresponds to that indicated on the rating plate fixed to the inside of the hood.
- For Class I appliances, check that the domestic power supply guarantees adequate earthing.

Connect the extractor to the exhaust flue through a pipe of minimum diameter 120 mm. The route of the flue must be as short as possible.

- Do not connect the extractor hood to exhaust ducts carrying combustion fumes (boilers, fireplaces, etc.).
- If the extractor is used in conjunction with non-electrical appliances (e.g. gas burning appliances), a sufficient degree of aeration must be guaranteed in the room in order to prevent the backflow of exhaust gas. The kitchen must have an opening communicating directly with the open air in order to guarantee the entry of clean air.

## USE

- The extractor hood has been designed exclusively for domestic use to eliminate kitchen smells.
- Never use the hood for purposes other than for which it has been designed.
- Never leave high naked flames under the hood when it is in operation.
- Adjust the flame intensity to direct it onto the bottom of the pan only, making sure that it does not engulf the sides.
- Deep fat fryers must be continuously monitored during use: overheated oil can burst into flames.
- The hood should not be used by children or persons not instructed in its correct use.

## MAINTENANCE

- Switch off or unplug the appliance from the mains supply before carrying out any maintenance work.
- Clean and/or replace the Filters after the specified time period.
- Clean the hood using a damp cloth and a neutral liquid detergent.

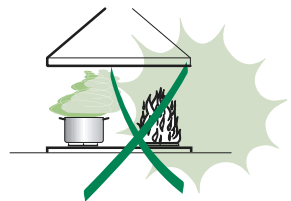

# CHARACTERISTICS

## Dimensions

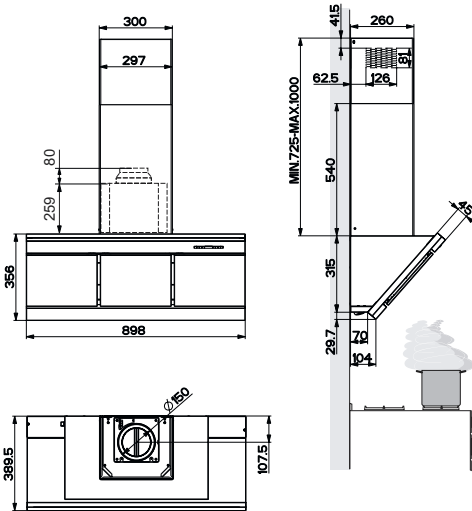

## Components

Ref.	Q.ty	Product Components
1	1	Hood Body, complete with: Controls, Light, Blower, Filters
2	1	Telescopic Chimney comprising:
2.1	1	Upper Section
2.2	1	Lower Section
9	1	Reducer Flange $\varnothing$ 150-120 mm
14.1	2	Air Outlet Connection Extension
15	1	Air Outlet Connection
Ref.	Q.ty	Installation Components
7.2.1	2	Upper Chimney Section Fixing Brackets
7.3	1	Air Outlet Connection Support
11	6	Wall Plugs
12a	6	Screws 4,2 x 44,4
12c	6	Screws 2,9 x 9,5
Q.ty	Documentation	
1	Instruction Manual	

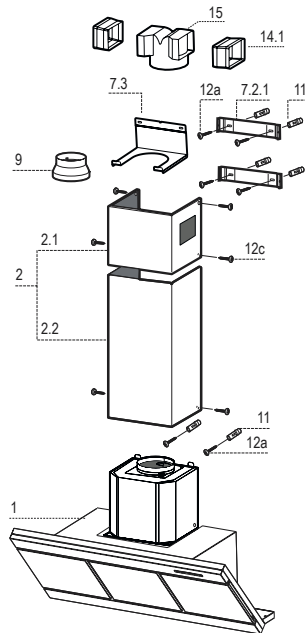

# INSTALLATION

## Wall drilling and bracket fixing

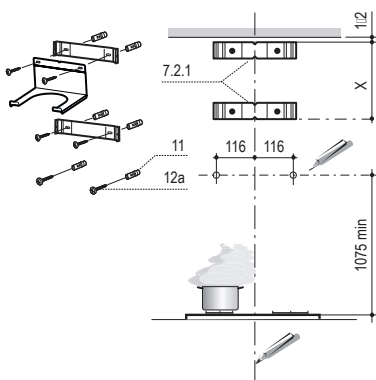

### Wall marking:

- Draw a vertical line on the supporting wall up to the ceiling, or as high as practical, at the centre of the area in which the hood will be installed.
- Draw a horizontal line at 1075 mm above the hob.
- Place bracket **7.2.1** on the wall as shown about 1-2 mm from the ceiling or upper limit aligning the centre (notch) with the vertical reference line.
- Mark the wall at the centres of the holes in the bracket.
- Place bracket **7.2.1** on the wall as shown at X mm below the first bracket (X = height of the upper chimney section supplied), aligning the centre (notch) with the vertical line.
- Mark the wall at the centres of the holes in the bracket.
- Mark a reference point as indicated at 116 mm from the vertical reference.
- Repeat this operation on the other side.
- Drill  $\varnothing$  8 mm holes at all the centre points marked.
- Insert the wall plugs **11** in the holes.
- Fix the lower bracket **7.2.1** using the **12a** screws (4,2 x 44,4) supplied.
- Fix the upper bracket **7.2.1** and the air outlet connection support **7.3** together using the 2 screws **12a** (4,2 x 44,4) supplied.
- Insert the two screws **12a** (4,2 x 44,4) supplied in the hood body fixing holes, leaving a gap of 5-6 mm between the wall and the head of the screw.

## Mounting the hood body

- Before attaching the hood body, tighten the two screws **Vr** located on the hood body mounting points.
- Hook the hood body onto the screws **12a**.
- Fully tighten support screws **12a**.
- Adjust screws **Vr** to level the hood body.

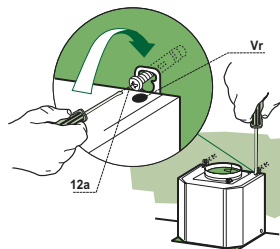

## Connections

### DUCTED VERSION AIR EXHAUST SYSTEM

When installing the ducted version, connect the hood to the chimney using either a flexible or rigid pipe  $\varnothing$  150 or 120 mm, the choice of which is left to the installer.

- To install a  $\varnothing$  120 mm air exhaust connection, insert the reducer flange **9** on the hood body outlet.
- Fix the pipe in position using sufficient pipe clamps (not supplied).
- Remove any activated charcoal filters.

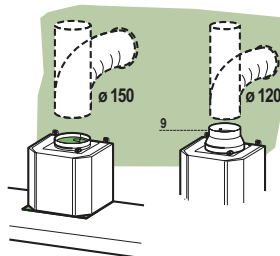

### RECIRCULATION VERSION AIR OUTLET

- Put connection **15** into the connection support **7.3**.
- Insert the connection extension pieces laterally **14.1** in connection **15**.
- Make sure that the outlet of the extension pieces **14.1** is horizontally and vertically aligned with the chimney outlets.
- Connect the air outlet connection **15** to the hood body outlet using either a flexible or rigid pipe  $\varnothing$  150 mm, the choice of which is left to the installer.
- Ensure that the activated charcoal filters have been inserted.

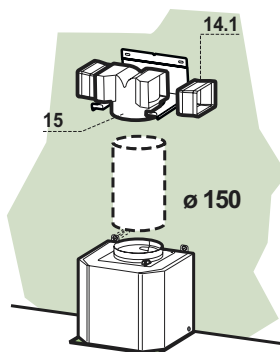

## ELECTRICAL CONNECTION

- Connect the hood to the mains through a two-pole switch having a contact gap of at least 3 mm.
- Remove the grease filters (see paragraph Maintenance) being sure that the connector of the feeding cable is correctly inserted in the socket placed on the side of the fan.

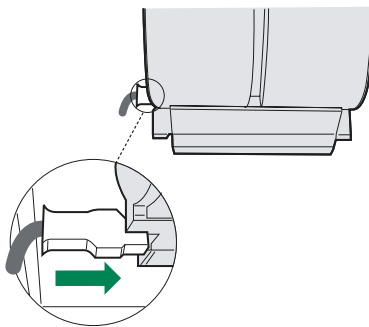

## Flue assembly

### Upper exhaust flue

- Slightly widen the two sides of the upper flue and hook them behind the brackets **7.2.1**, making sure that they are well seated.
- Secure the sides to the brackets using the 4 screws **12c** (2,9 x 9,5) supplied.
- Make sure that the outlet of the extensions pieces is aligned with the chimney outlets.

### Lower exhaust flue

- Slightly widen the two sides of the flue and hook them between the upper flue and the wall, making sure that they are well seated.
- Fix the lower part laterally to the hood body using the 2 screws **12c** (2,9 x 9,5) supplied.

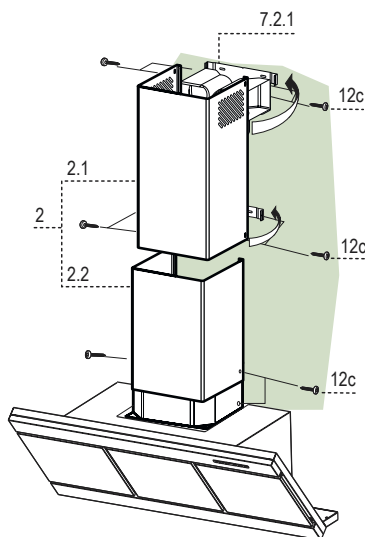



## Control board

Key	Function	Display
<b>A</b>	Switches the extractor motor on and off at the latest selected speed	Indicates the selected speed.
<b>B</b>	Decreases the suction speed.	
<b>C</b>	Increases the suction speed.	
<b>D</b>	By pressing this key it is possible to activate the intensive speed from any previously selected speed. The intensive speed can be activated even when the motor is OFF. This speed has been timed at 10 minutes. After that time the system activates automatically the latest selected speed. This function is suitable for cooking conditions when vapours and smells are of the utmost emission.	<b>HI</b> appears. The spot down on the right side flashes once a second.
<b>E</b>	By pressing this key it is possible to set up the motor to a suction speed at 100 m <sup>3</sup> /h lasting 10 minutes every hour. After this the motor switches off automatically.  When the filter saturation is going on it is possible to reset the alarm by pressing this key for about 3 seconds. The indication is visible only when the motor is off.	Indicates the <b>24-function</b> . The spot down on the right side flashes and the motor is on.  Once the process is finished the previous indication disappears: <b>FF</b> Indicates that the metal grease filters saturation alarm has been triggered, and the filters need to be washed. The alarm is triggered after 100 working hours. <b>EF</b> Indicates that the charcoal filter saturation alarm has been triggered, and the filter has to be replaced; the metal grease filters must also be washed. The charcoal filter is triggered after 200 working hours.
<b>F</b>	By pressing this key it is possible to set the delayed shutdown of the appliance to 30 minutes. This function is suitable for a complete elimination of the residual smells. It can be activated at any position, and it is deactivated by pressing the key again or by switching off the motor.	Indicates alternately the selected speed of the hood and the time left before the hood shutdown. The spot down on the right side flashes.
<b>G</b>	Turns light on and off .	
<b>H</b>	Turns light on and off at reduced intensity.	

# MAINTENANCE

## Cleaning the Comfort Panels

- Pull the Comfort Panel to open it.
- Disconnect the panel from the hood canopy by sliding the fixing pin lever.
- The comfort panel must never be washed in a dishwasher.
- Clean the outside using a damp cloth and neutral liquid detergent.
- Clean the inside as well using a damp cloth and neutral detergent; do not use wet cloths or sponges, or jets of water; do not use abrasive substances.
- When the above operation has been completed, hook the panel back to the hood canopy and close it by turning the knob in the opposite direction.

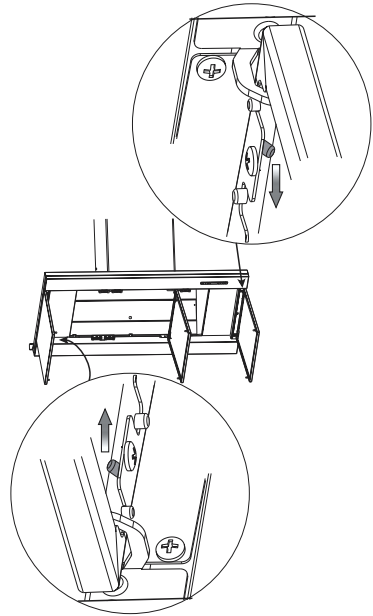

## Metal grease filters

Filters can be washed in the dish machine. They need to be washed when **FF**-sign appears on the display or in any case every 2 months, or even more frequently in case of particularly intensive use of the hood.

### Alarm reset

- Switch off the hood and the lights. If the 24h-function has been activated this has to be deactivated.
- Press the **E**-key till the display is unlit.

### Cleaning the filters

- Pull the comfort panels to open them.
- Remove the filters one by one pushing them towards the back side of the hood unit and simultaneously pulling downwards.
- Any kind of bending of the filters has to be avoided when washing them. Before fitting them again into the hood make sure that they are completely dry. (The colour of the filter surface may change throughout the time but this has no influence to the filter efficiency).
- When fitting the filters into the hood pay attention that they are mounted in correct position the handle facing outwards.
- Close the comfort panel.

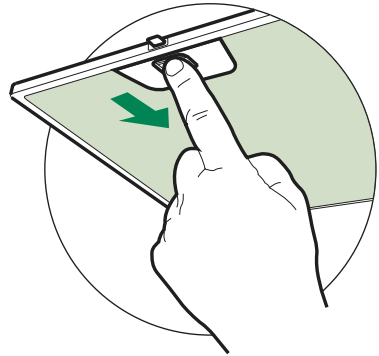

## Charcoal filter (recycling version)

- This filter cannot be washed or regenerated. It must be replaced when the **EF** appears on the display or at least once every 4 months.

### Activation of the alarm signal

- In the recycling version hoods the filter saturation alarm must be activated during the installation or later.
- Switch off the hood and the lights.
- Disconnect the hood from the mains supply.
- When restoring the connection press and hold **B**-key.
- When releasing the key two rotating rectangles appear on the display.
- **Within 3 seconds** press the **B**-key until a flashing confirmation appears on the display:
  - 2 flashes with **EF** - charcoal filter saturation alarm **ACTIVATED**
  - 1 flash with **EF** - charcoal filter saturation alarm **DEACTIVATED**.

## REPLACING THE CHARCOAL FILTER

### Reset of the alarm signal

- Switch off the hood and the lighting. If the 24h-function has been activated this has to be deactivated.
- Press the E-key until the display is unlit.

### Replacing of the filter

- Open the comfort panels pulling them downwards.
- Remove the metal grease filters.
- Remove the saturated charcoal filter by releasing the fixing hooks
- Fit the new filter and fasten it in its correct position.
- Put the metal grease filters in their seats.
- Close the comfort panels.

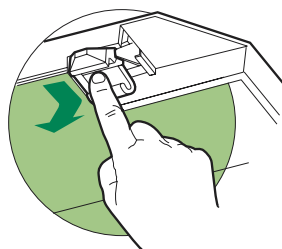

## Lighting

### LIGHT REPLACEMENT

#### 20 W halogen light.

- Remove the 2 screws fixing the Lighting support, and pull it out of from the Hood.
- Extract the lamp from the Support.
- Replace with another of the same type, making sure that the two pins are properly inserted in the lamp holder socket holes.
- Replace the Support, fixing it in place with the two screws removed as above.

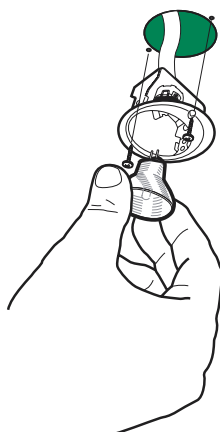







Il simbolo  sul prodotto o sulla confezione indica che il prodotto non deve essere considerato come un normale rifiuto domestico, ma deve essere portato nel punto di raccolta appropriato per il riciclaggio di apparecchiature elettriche ed elettroniche. Provvedendo a smaltire questo prodotto in modo appropriato, si contribuisce a evitare potenziali conseguenze negative per l'ambiente e per la salute, che potrebbero derivare da uno smaltimento inadeguato del prodotto. Per informazioni più dettagliate sul riciclaggio di questo prodotto, contattare l'ufficio comunale, il servizio locale di smaltimento rifiuti o il negozio in cui è stato acquistato il prodotto.



The symbol  on the product or on its packaging indicates that this product may not be treated as household waste. Instead it shall be handed over to the applicable collection point for the recycling of electrical and electronic equipment. By ensuring this product is disposed of correctly, you will help prevent potential negative consequences for the environment and human health, which could otherwise be caused by inappropriate waste handling of this product. For more detailed information about recycling of this product, please contact your local city office, your household waste disposal service or the shop where you purchased the product.



Le symbole  sur le produit ou son emballage indique que ce produit ne peut être traité comme déchet ménager. Il doit plutôt être remis au point de ramassage concerné, se chargeant du recyclage du matériel électrique et électronique. En vous assurant que ce produit est éliminé correctement, vous favorisez la prévention des conséquences négatives pour l'environnement et la santé humaine qui, sinon, seraient le résultat d'un traitement inapproprié des déchets de ce produit. Pour obtenir plus de détails sur le recyclage de ce produit, veuillez prendre contact avec le bureau municipal de votre région, votre service d'élimination des déchets ménagers ou le magasin où vous avez acheté le produit.



Das Symbol  auf dem Produkt oder seiner Verpackung weist darauf hin, dass dieses Produkt nicht als normaler Haushaltsabfall zu behandeln ist, sondern an einem Sammelpunkt für das Recycling von elektrischen und elektronischen Geräten abgegeben werden muss. Durch Ihren Beitrag zum korrekten Entsorgen dieses Produkts schützen Sie die Umwelt und die Gesundheit Ihrer Mitmenschen. Umwelt und Gesundheit werden durch falsches Entsorgen gefährdet. Weitere Informationen über das Recycling dieses Produkts erhalten Sie von Ihrem Rathaus, Ihrer Müllabfuhr oder dem Geschäft, in dem Sie das Produkt gekauft haben.



Ürün veya paketi üzerindeki  sembolü, bu ürünün normal bir evsel atık olarak görülmemesi ve bu tip elektrikli veya elektronik cihazların atıldığı dönüşümlü toplama noktalarına terkedilmesi gerektiğine işaret eder. Bu ürünü gerektiği gibi elimine etme kurallarına uymazsanız çevre ve insan sağlığı üzerindeki olumsuz etkilerini bertaraf etmeye katkı sağlamış olursunuz. Bu ürünün geri dönüşüm koşulları hakkında daha ayrıntılı bilgi için hudutları içinde bulunduğunuz belediyenin ilgili diareasine, atık yoketme servisine veya ürünün satıcısına danışınız.

Franke S.p.a.  
Via Pignolini,2  
37019 Peschiera del Garda (VR)  
www.franke.it