

Franke Turbo WD-500

Specification Sheet



- High-speed 2600 R.P.M. permanent magnet motor produces more power per Kilo
- High torque dual magnetic motor
- Stainless steel grinding components
- Professional 3-bolt mount system
- Air Switch included
- Sound insulated for quiet operation
- Easy to install
- Continuous feed
- Nationwide servicing
- 8 year warranty

Dimensions

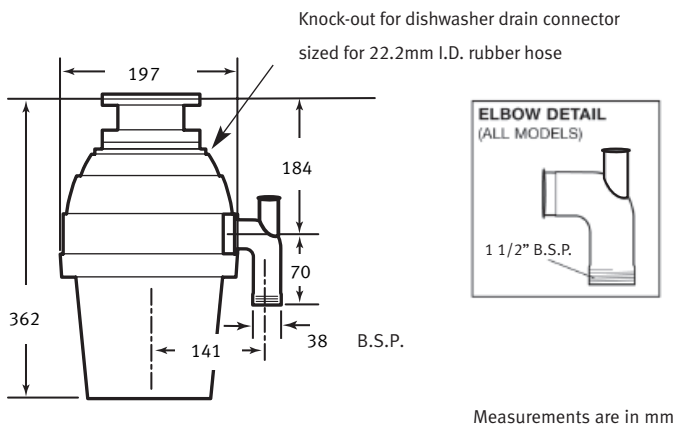

8 Year Warranty

The Franke Turbo WD-500 waste disposal system carries an 8 year service warranty that covers all service and parts. This warranty demonstrates the confidence we have in Franke quality.

The Franke warranty policy

The Franke service warranty covers all replacement parts to correct defects in material and workmanship for 8 years from the date of purchase. If service is requested during the warranty period, Franke will replace or repair the disposer at no charge.

Specifications

Motor Horsepower	1/2 H.P.
Motor Speed R.P.M.	2600
Voltage	220-240
Hz	50/60
Watts	490
Motor Type	Permanent Magnet
Power Cord	Attached
Sink Flange	Stainless Steel
Stopper	Positive Seal
Waste Elbow	ABS
Feed	Continuous
Grind Ring	Stainless Steel
Swivel Impellers	Stainless Steel
Turntable	Stainless Steel
Hopper	Glass Filled Nylon
Grinding Chamber	Corrosion Proof Glass Filled Thermoset Polyester
Bearings	Permanently Lubricated; Sleeve Type
Overload Protector	Manual Reset Type
Sound Dampening Shell	Yes - Foam Insulated

You are advised to check with your local authority if you are in any doubt about the Waste Disposal Unit being compatible with the sewerage system.

For kitchens without compromise.

