

mira ***enhance***

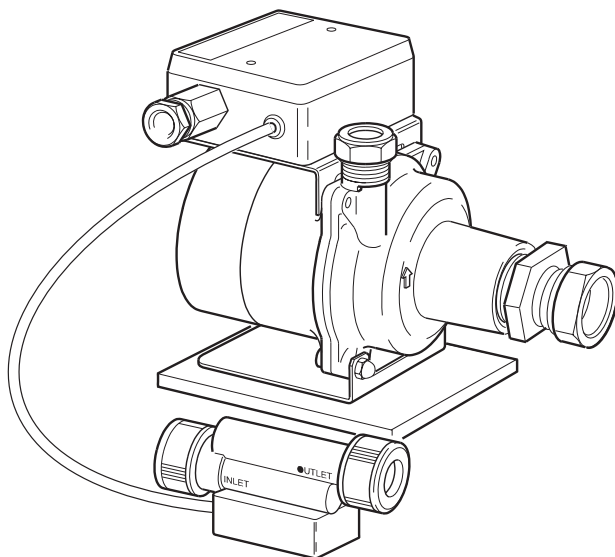

SHOWER PUMP

Installation & User Guide

THESE INSTRUCTIONS ARE TO BE LEFT WITH THE USER

Contents

Section	Page
1 Important Safety Information	3
2 Introduction	
Description	5
Operation	5
3 Specifications:	
Weight	7
Dimensions	7
Power Supplies	7
Water Standards	8
Connections	8
4 Pack Contents Checklist:	
Mira Enhance Shower Pump	9
Documentation	9
5 Installation:	
Plumbing	10
Electrical	14
6 Commissioning	
Commissioning	17
7 Maintenance:	
Fault Diagnosis	18
Appendices:	
1 Parts List:	
Spare Parts	20
Guarantee, Customer Care Policy, and How to contact us	
Back cover	

1. WARNING!

- 1.1. Products manufactured by Mira are precision engineered and should give continuous superior and safe performance provided they are installed, operated and maintained in accordance with the instructions and recommendations given in this manual.
- 1.2. Installation must be carried out by qualified personnel only. Failure to comply with these safety instructions will cause risk to people and equipment and may invalidate the guarantee.

Identified hazards are highlighted by the following symbols:

Danger from general causes: 

Danger from electrical causes: 

Instructions which if ignored could cause damage or impair the function of the pump are highlighted by the word: **ATTENTION**

2. Caution!

- 2.1. Read all of these instructions and retain this manual for later use.
- 2.2. Pass on this manual in the event of change of ownership of the installation site.
- 2.3. The plumbing installation must comply with the requirements of UK Water Regulations/Bye-laws (Scotland), Building Regulations or any particular regulations and practices, specified by the local water company or water undertakers. The installation should be carried out by a plumber or contractor who is registered, or is a member of, an association such as:
 - 2.3.1. Institute of Plumbing (IOP), throughout the UK.
 - 2.3.2. National Association of Plumbing, Heating and Mechanical Services Contractors (NAPH & MSC), England and Wales.
 - 2.3.3. Scottish and Northern Ireland Plumbing Employers' Federation (SNIPEF), Scotland and Northern Ireland.



WARNING - THIS APPLIANCE MUST BE EARTHED.

- 2.4. WARNING! THIS APPLIANCE MUST BE EARTHED. MAKE SURE SUPPLEMENTARY BONDING COMPLIES WITH THE "REQUIREMENTS FORELECTRICALINSTALLATIONS"**, or any particular regulations or practices, specified by the local electricity supply company.

The pump is supplied with a pre-wired flow switch and mains cable and must be permanently connected to the fixed wiring of the mains system.

Warning! Do not use a plug and socket.

- 2.5.** The inclusion of a Residual Current Device (RCD) (Earth trip) with a trip current of 30mA is recommended. This may already be part of the consumer unit.
- 2.7.** Anyone who may have difficulty understanding or operating the controls of any shower should be attended whilst showering. Particular consideration should be given to the young, the elderly, the infirm, or anyone inexperienced in the correct operation of the controls.

Standards and Approvals

1. The Mira Enhance complies with all the relevant directives for CE marking.

Thank you for purchasing a quality Mira product. To enjoy the full potential of your new product, please take time to read this guide thoroughly, having done so, keep it safe for future reference.

1. Description

The Mira Enhance single impeller centrifugal pump is designed to receive a single gravity feed from a mixing valve and provide a pressurized supply to a fixed shower head or shower handset. (Refer to Figures 2 and 3). The pump is not suitable for an installation in the system layouts shown in Figures 4 and 5.

The pump is more effective when pushing water along a pipe rather than pulling. Thus the pump is best positioned as close to the hot water or blend water source as possible to reduce cavitation (air bubbles) in the pipes. The greater the static (inlet) water pressure on the pump the better it will operate. Thus positioning a pump at high level is not advantageous, and may result in inferior performance.

Due consideration should be made to the pump position as any noise generated may be amplified by installation conditions such as reverberant panels etc. The pump motor is air cooled and it is important that the flow of air around the motor is not impeded. The pump should be sited in a frost free area and inlet/outlet pipework layouts which can create significant airlocks are best avoided.

ATTENTION: Pipework on the outlet side of the pump that could be prone to airlocks can be fitted with a float-type automatic air vent (bottle vent) at the highest point as shown in Figure 3. This will ensure that air released in the hot water during the pumping and heating process can be vented.

The stored hot and cold water volumes should be sufficient for the required duty. Typical minimum flow rates are 10 l/min for a pulsating handset or overhead shower. The manufacturer's data for the outlet fittings should be consulted.

2. Operation

The pump would normally start automatically when the mixing valve is set to open. The contacts of the flow switch at the pump outlet close when the flow rate in the outlet pipe is more than 1.4 l/min. When this occurs the electrical circuit to the motor is completed and the pump operates. The opposite action occurs when the mixing valve is set to shut.

A vertical distance of 300 mm between the water discharge point through the shower outlet and the base of the cistern would typically achieve the flow rate required. However, long pipe runs or restrictive terminal fittings will increase the gravity head required to produce the required flow.

To overcome an initial low flow rate in the outlet pipe it is possible to bypass the function of the flow switch by the addition of a momentary action switch connected in parallel with the flow switch (Refer to Figure 6). When the mixing valve is set to on and the momentary action switch operated, the pump will run. The pump will then maintain the necessary flow rate in the outlet pipe and will continue to operate until the mixing valve is set to off.

Suitable momentary action switches are as follows:

MK4408P		wall mounted seal switch
Crabtree CT2147	}	ceiling mounted pull cord switch
MK3190RCWH1(5A)		

1. Weight

Mira Enhance Shower Pump = 2.7 kg (Pump only)

2. Dimensions

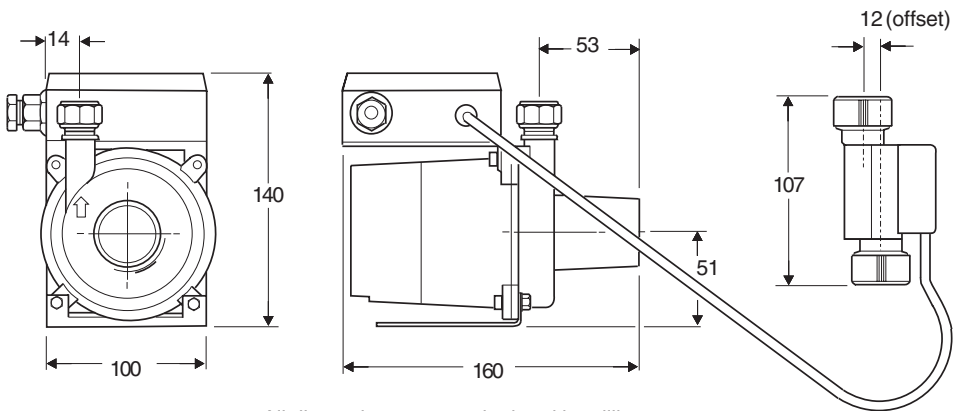

All dimensions are nominal and in millimetres

External Dimensions
Figure 1

3. Power Supplies

- 3.1. **Single Phase** 230V 50Hz fused supply through a 5A fused connection unit or equivalent, refer to Figure 6.
- 3.2. **Absorbed Power** Approximately 85W during normal working conditions.

4. Water Standards

- 4.1. This product complies with all relevant directives for CE marking.
- 4.2. **Maximum Hot Water Temperature** 80°C. It is recommended that stored water temperatures should never exceed 65°C. The use of hot water above 60°C may lead to cavitation (air bubbles) which will increase pump noise and reduce the service life of the product. A temperature of 60°C is considered sufficient to meet all normal requirements and will minimize the deposition of scale in hard water areas.
- 4.3. **Delivery Rates** See Pump Performance Graph. Terminal fittings and associated pipe work will reduce this figure.

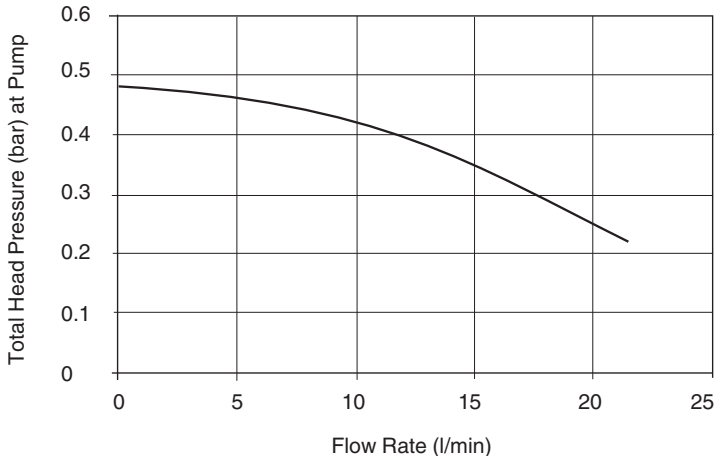

Mira Enhance Shower Pump Performance Graph

- 4.4. **ATTENTION: Inlet Pressure** Maximum inlet static pressure 3 bar (30m head).

5. Connections

5.1. Plumbing

Inlet - compression fitting to fit 22mm copper pipe

Outlet - compression fitting to fit 15mm copper pipe.

FS4 Flow switch - push-fit fitting to fit 15mm copper pipe.

1. Mira Enhance Shower Pump

Tick the appropriate boxes to familiarize yourself with the part names and to confirm that the parts are included.

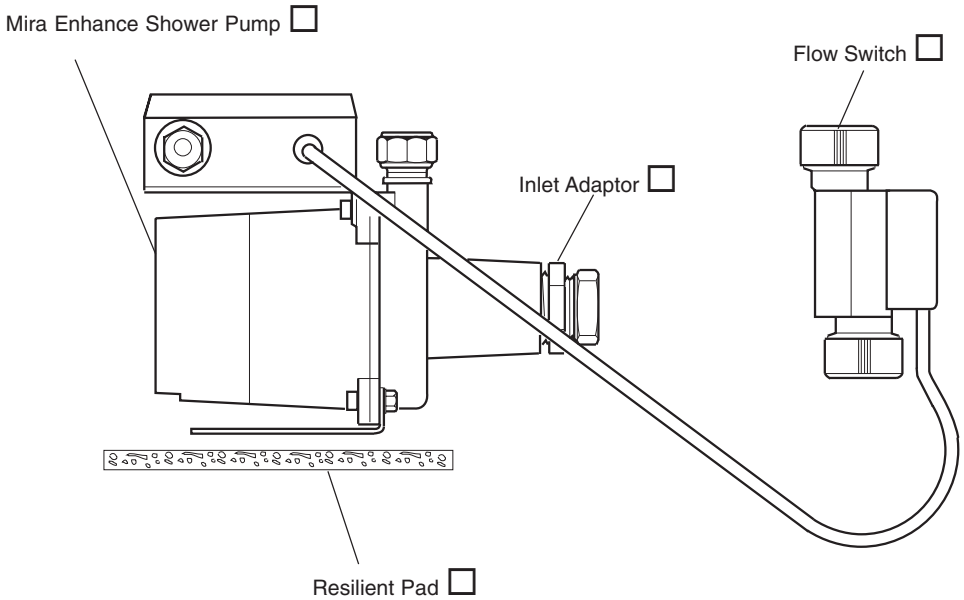

2. Documentation

1 x Installation, Operation and Maintenance Guide

1 x Customer Support Brochure

1. Plumbing

WARNING

ATTENTION: DO NOT FIT INLET CHECK VALVES. INLET CHECK VALVES CAN SERIOUSLY DAMAGE THE PUMP.

- 1.1. **ATTENTION:** The pump must be mounted in a horizontal position with the outlet connection vertically upwards. The operation of the flow switch will be impaired in any other position.
- 1.2. Operational difficulties may be experienced if plumbing layouts shown in Figures 4 and 5 are used.
- 1.3. **ATTENTION:** The pump and pipes must not be installed against wood, plastic or any other material which may be effected by heat from the pump.
- 1.4. The hot feed from the cylinder must be as illustrated. Side entry cylinder bosses are not recommended. A drop in cylinder water level could expose a top entry immersion element. Air in water gathers at the edge of the cylinder, and in the centre, during the heating process, before travelling up the vent.
- 1.5. **ATTENTION:** Water pumps can develop leaks and should, therefore, not be situated where seepage may go undetected or cause damage. The pump must be installed such that it is accessible for servicing or removal. When servicing or disconnecting, small amounts of water may drain from the unit and pipework.
- 1.6. Pump performance is maximised by the use of 22 mm pipe, especially on the inlet pipework and where long outlet pipe runs are used.
- 1.7. Pipe jointing should be via P.T.F.E. tape or fluid sealant. Do not use hemp and paste which may affect the operation of the flow switch and plastic internal components.
- 1.8. **ATTENTION:** Care should be taken when using soldering fluxes. Protect the pump from damage whilst making soldered connections as some fluxes cause damage to plastic components.
- 1.9.  Pipe connections to the pump should be supported to reduce strain and must be correctly aligned prior to installing the pump to reduce the risk of scolding.

- 1.10.** It is recommended that inlet/outlet isolation valves are fitted within close proximity of the pump to permit isolation for servicing (See Figures 2 & 3).
- 1.11.**  Ensure no fluid drips onto the pump motor or its electrical connections during installation, venting or operation as when the pump is energised this may create a risk of electric shock.
- 1.12.** Joint and assemble the adapter to the pump inlet. Do not overtighten the adapter.
- 1.13.** Install a short length of 15mm pipe at the pump outlet, tighten the compression joint. Push the flow switch onto this pipe (end marked Inlet first) ensuring that the flow switch is fitted vertically (See to Figure 7).
- 1.14.** Place the pump on its resilient pad and complete the inlet and outlet pipe work.

Key to symbols used in the system layouts:

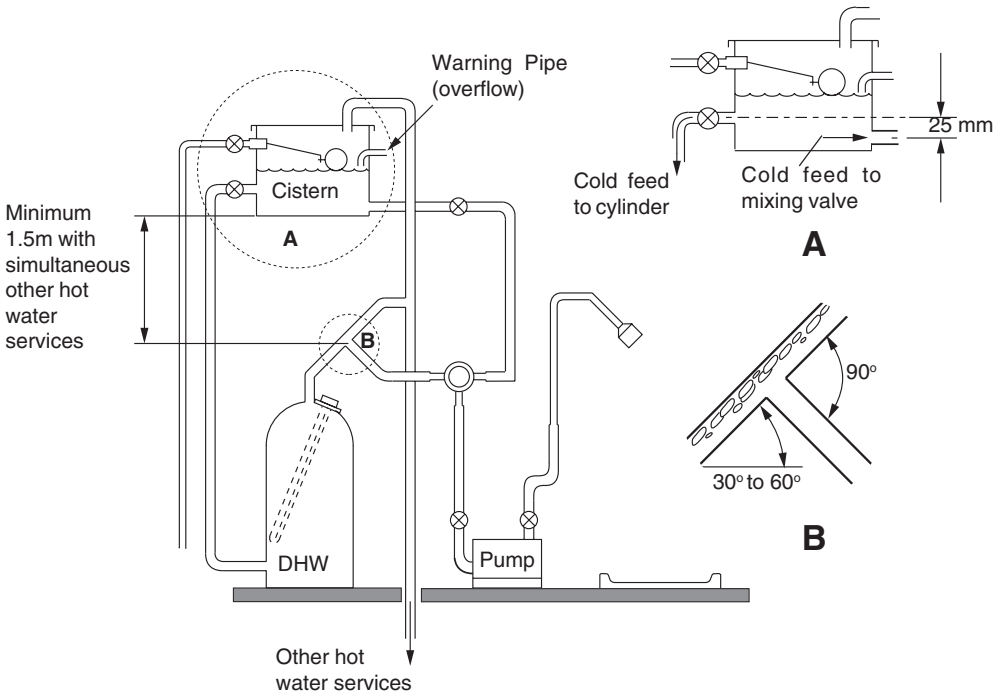
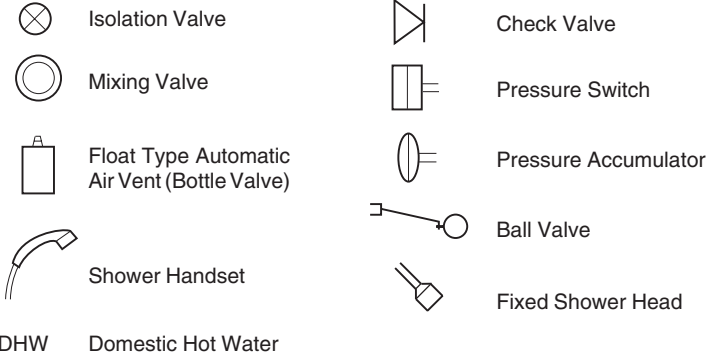

System Layout
Figure 2

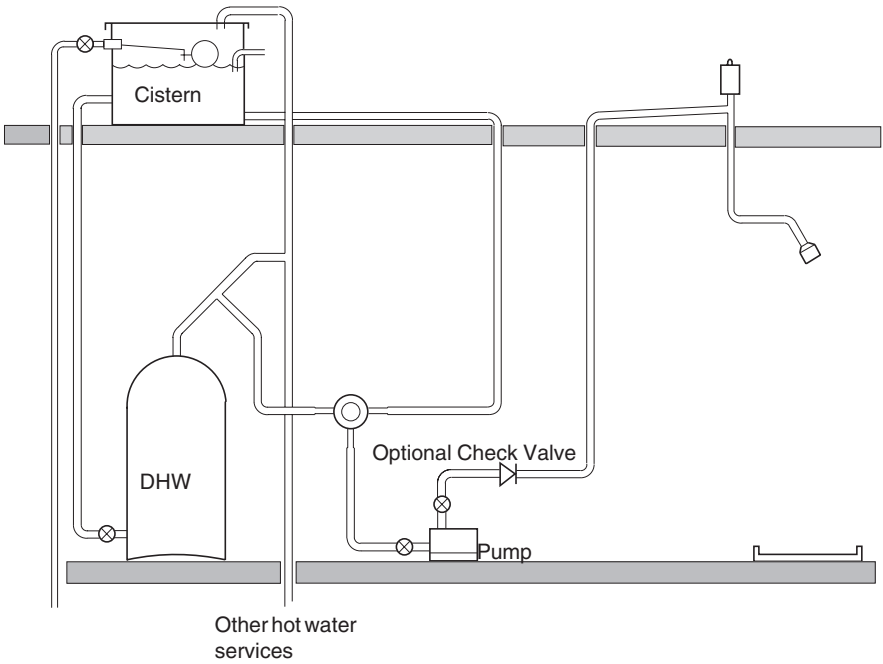

System Layout with High Level Pipework
Figure 3

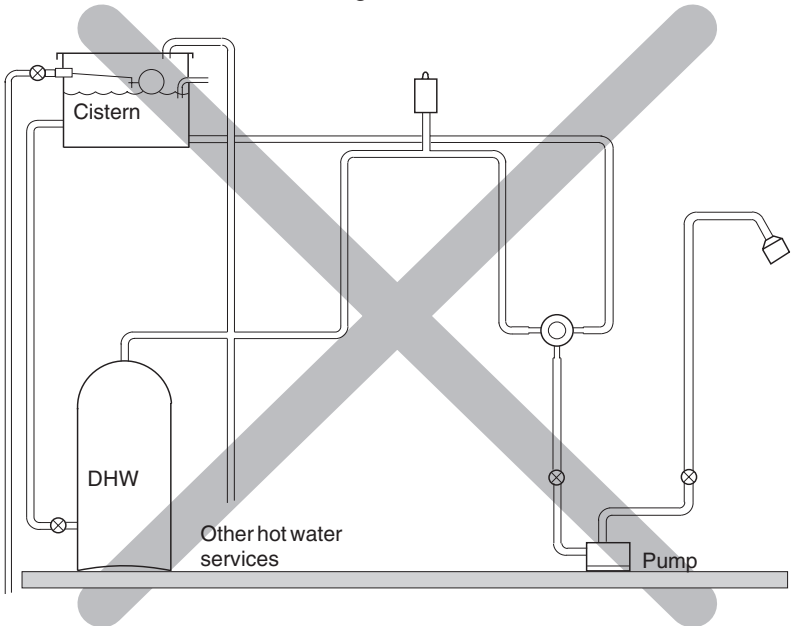

Unsuitable System Layout
Figure 4

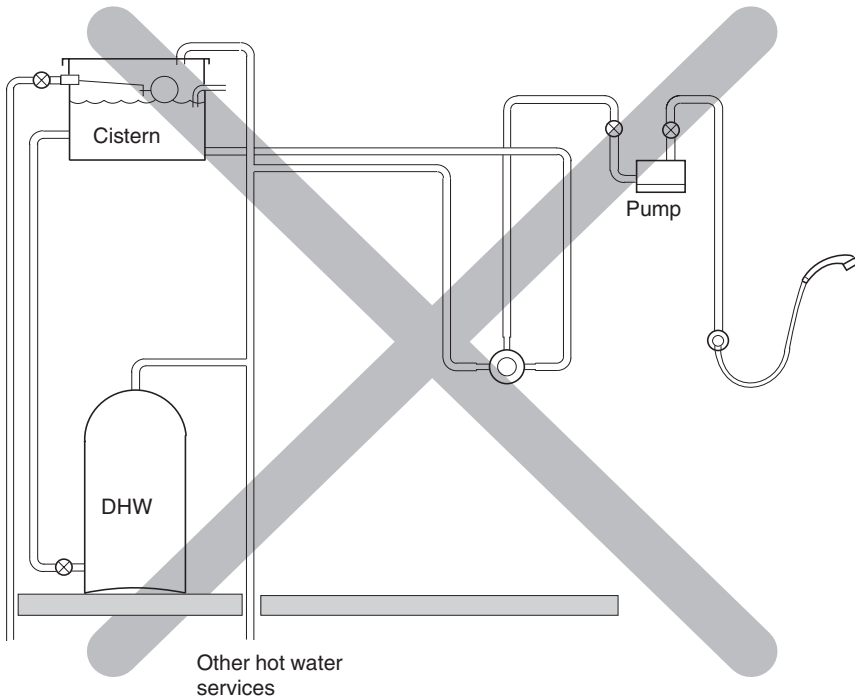

Unsuitable System Layout
Figure 5

2. Electrical



WARNING: THIS APPLIANCE MUST BE EARTHED.

All electrical installations must comply with current IEE regulations and be undertaken by a qualified person.

- 2.1. The power to the pump should be through a double pole, switched, fused connection unit or equivalent with a 5A fuse (Refer to Figure 6), the contact separation in each pole should be at least 3mm. A cable with a minimum core area of 0.75mm² should be used from the fuse to the pump.
- 2.2. Remove the terminal cover (single screw) and connect the electrical supply and, only if necessary, connect the momentary action switch to the appropriate terminals (Refer to Section 2, Operation):

L = Brown, N = Blue, E = Yellow/Green, FS = Flow Switch and External Switching. (Refer to Figure 6). Ensure that the cable gland nut is tightened to provide strain relief.

- 2.3.  Cross bond the inlet and outlet pipework, using a minimum 6mm² cable and bonding clamps (Refer to Figure 7). Plastic pipes do not require bonding.

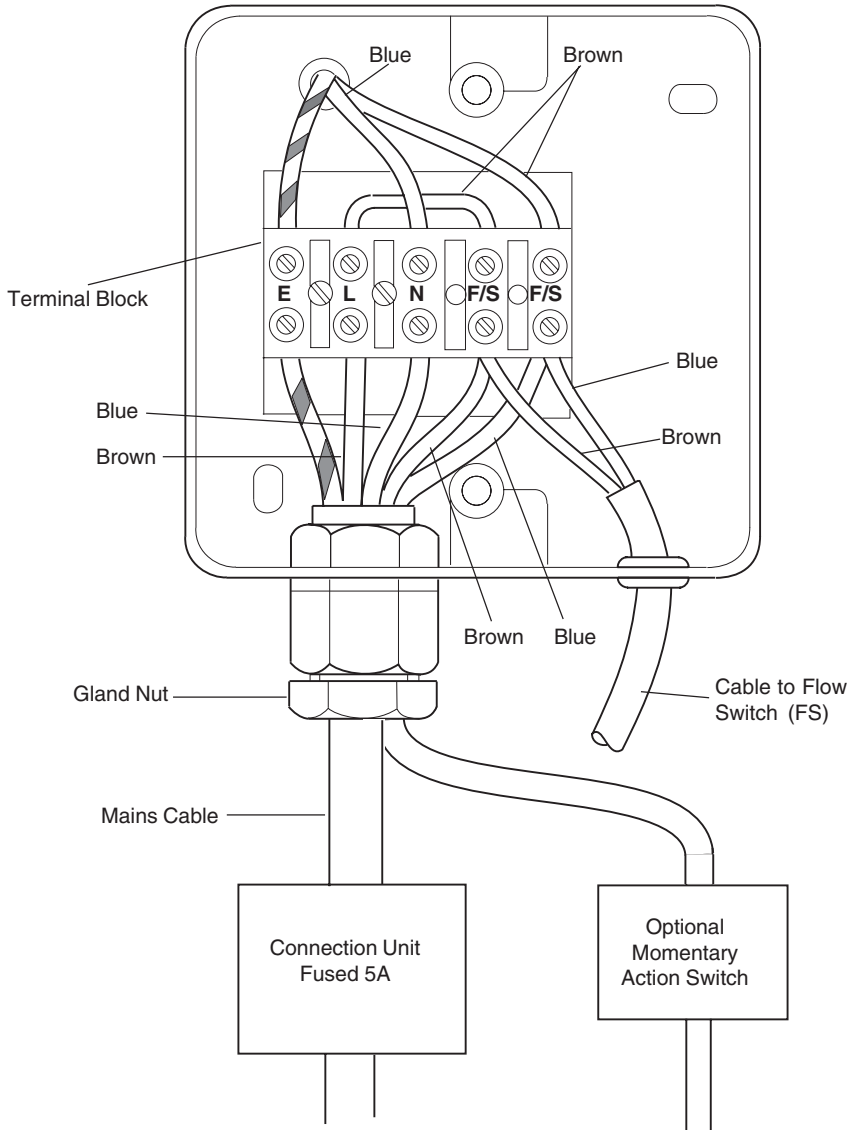

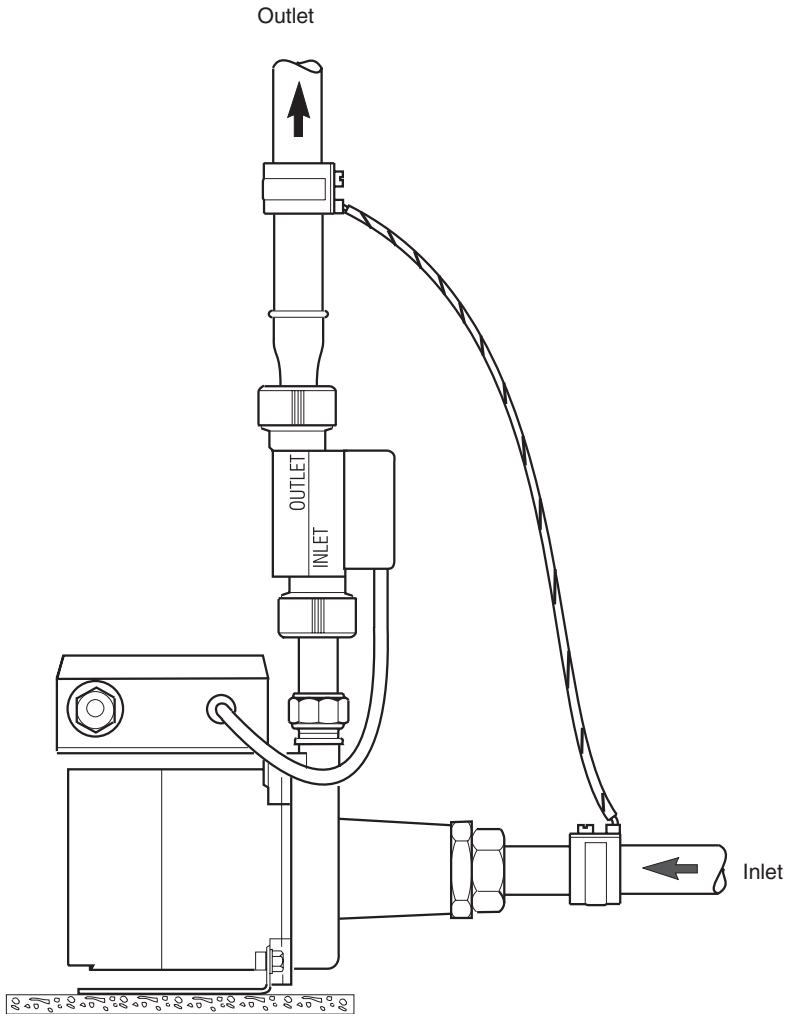

Wiring Diagram
Figure 6



Pipe Bonding Details
Figure 7

1. Commissioning

- 1.1.  Proceed with caution due to the risk from hot water and scolding.
 - 1.2.  Ensure that the pump is electrically isolated.
 - 1.3. Ensure that all the isolating valves are fully open and that the pump chamber is fully flooded.
-  THIS PUMP MUST **NOT** BE RUN DRY. IF IT IS, SEAL AND BEARING DAMAGE MAY OCCUR.
- 1.4. Open the shower fully. Water should flow from the outlet under the pressure of gravity. Leave the outlet open for a short period of time to allow the air to be expelled from the system. Turn off the shower and check the pump, shower and the interconnecting pipework for leaks.
 - 1.5. If no water comes out of the outlet, then the system may be airlocked or the shower may be fitted in a negative head situation. Refer to Section 7, Maintenance: "Fault Diagnosis" or Section 2, Operation.
 - 1.6. Switch on the power to the pump.
 - 1.7. Open the shower valve and check that the pump has operated automatically.
 - 1.8. The flow rate must be at least 1.4 l/min for the flow switch to operate.
 - 1.9. If the pump is not operating correctly repeat the commissioning procedure,

1. Fault Diagnosis

Read the section "**Important Safety Information**" first.

Providing the shower pump has been correctly installed and is operated in accordance with the instructions contained in this guide, difficulties should not arise. If any maintenance is required then it must be carried out by a competent tradesperson for whom the fault diagnosis and maintenance instructions are provided. Before replacing any parts ensure that the underlying cause of the malfunction has been resolved.

1.1. Pump does not start

1.1.1. Check adequate gravity flow (1.4 l/m).



Isolate power and water and check:

1.1.2. Supply fuse, mains supply and the fused connection unit.

1.1.3. Free operation of the flow switch, fitted externally in the outlet vertical pipe of the pump, with the Inlet at the bottom.

1.2. Pump does not stop after the water flow has ceased



Isolate power and water and check:

1.2.1. Check that the flow switch is fitted correctly (Refer to Section 5, Installation).

1.2.2. Free movement of magnetic float within flow switch.

1.2.3. Any external switching connected operating correctly.

1.3. Pump operation occurs momentarily

If pump operation occurs momentarily, particularly when other hot water services that are not on the pumped circuit are used, or an on/off pulsating operation occurs when the shower is turned off, check:

1.3.1. There are no air-locks in the pump outlet pipe work. These will cause water movement through the pump by compression of the air. Reroute the pipe work or fit float type automatic air vents at air collection points. (Refer to Figure 3).

1.3.2. Fit check valve onto pump outlet after flow switch to prevent water surging in the pipe work. This may increase the pressure required to start the pump (Refer to Figure 3).

1.4. Flow starts adequately and drops after a short time

Check:

1.4.1. Sufficient stored cold water.

1.4.2. Pipe work that is prone to air-locking should be rerouted to be self venting when not in use. Float type Automatic Air Vents are, in general, NOT advisable for pump **inlet** pipe work, as a negative pump pressure will allow air to be sucked in through Automatic Air Vents. The pressure at the desired vent position can approximately be determined using the Mira green book 'A Guide to Domestic Pumped Shower Systems', to check whether it remains positive under dynamic conditions.

226.08 Resilient Pad
872.06 Flow Switch

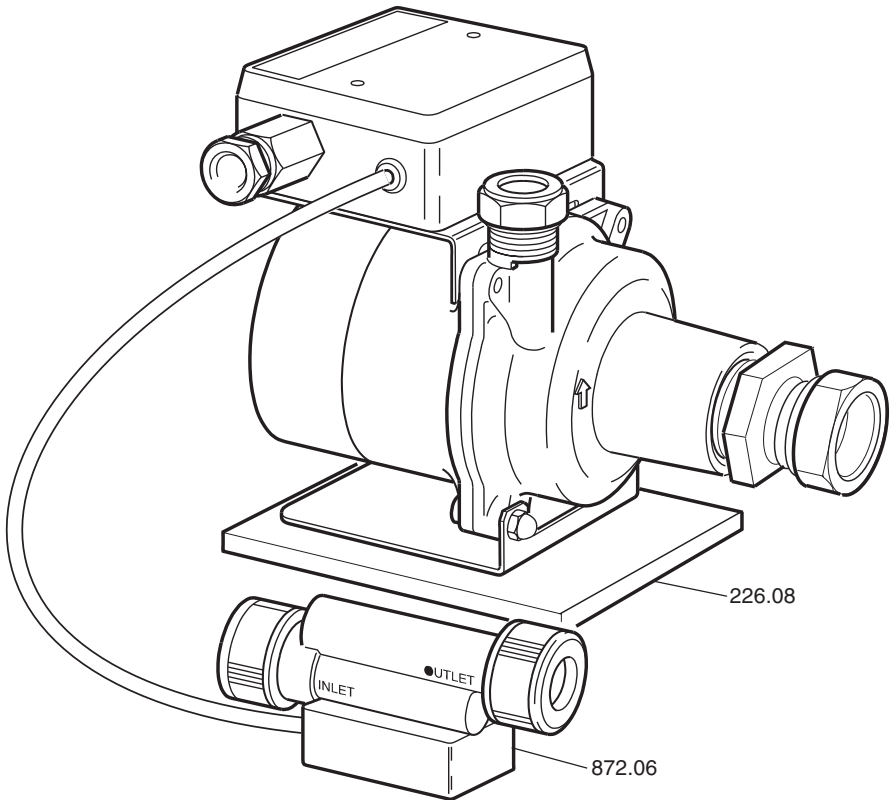

Notes

Notes

Notes

Customer Service

Guarantee of Quality

Mira Showers guarantee products against any defect of materials or workmanship for one year from the date of purchase (2 years for Mira Select and 3 years for Mira Excel ranges).

To validate the guarantee, please return your completed registration card.

Within the guarantee period we will resolve defects, free of charge, by repairing or replacing parts or modules as we may choose.

To be free of charge, service work must only be undertaken by Mira Showers or our approved agents in Northern Ireland and Republic of Ireland.

Service under this guarantee does not affect the expiry date. The guarantee on any exchanged parts or product ends when the normal product guarantee period expires.

Not covered by this guarantee:

Damage or defects arising from incorrect installation, improper use or lack of maintenance, including build-up of limescale.

Damage or defects if the product is taken apart, repaired or modified by any person not authorised by Mira Showers or our approved agents.

This guarantee is in addition to your statutory and other legal rights.

Before using your shower

Please take the time to read and understand the operating and safety instructions detailed in this manual.

What to do if something goes wrong

If when you first use your shower it doesn't function correctly, first contact your installer to check that installation and commissioning are satisfactory and in accordance with the instructions in this manual. We are on-hand to offer you or your installer any advice you may need.

Should this not resolve the difficulty, simply contact our Customer Services who will give every assistance, and if necessary arrange for our service engineer to visit.

If later the performance of your shower declines, consult this manual to see whether simple home maintenance is required. Please call our Customer Services to talk the difficulty through, request service under guarantee if applicable, or take advantage of our comprehensive After-Sales service.

After Sales Service

Our Customer Services Team is comprehensively trained to provide every assistance you may need: help and advice, spare parts or a service visit.

As part of our quality and training programme calls may be recorded or monitored

Spare Parts

We maintain an extensive stock of spares, and aim to have functional parts available for ten years from the date of final manufacture of the product.

Spares can be purchased from approved stockists or merchants (locations on request) or direct from Customer Services.

Spares direct will normally be despatched within two working days. Payment can be made by Visa or Access at the time of ordering. Should payment by cheque be preferred a proforma invoice will be sent.

Note! In the interests of safety, spares requiring exposure to mains voltage can only be sent to competent persons.

Service

Our Service Force is available to provide a quality service at a reasonable cost. You will have the assurance of a Mira trained engineer/agent, genuine Mira spares – and a 12 month guarantee on the repair.

Payment should be made directly to the Service Engineer/Agent, using Visa, Access or a cheque supported by a banker's card.

To contact us:

England, Scotland & Wales

Mira Showers Customer Services

Telephone: 0870 241 0888

8.30am to 5pm Working days (4.30pm Fri)

8.30 am to 12.30pm Saturday

E-mail: Mira_technical@mirashowers.com

Fax: 01242 282595

By Post: Cromwell Road

Cheltenham

Gloucester GL52 5EP

For Customers in Northern Ireland

Wm H Leech & Son Ltd

Telephone: 028 9044 9257 – Mon to Fri 9 am-5pm

Fax: 028 9044 9234 – 24 hours

Post: Maryland Industrial Estate

Ballygowan Road

Moneyreagh, Co Down

BT23 6BL

For Customers in Republic of Ireland

Modern Plant Ltd

Telephone: Dublin 01 4591344 - Mon to Fri 9am to 5pm

Fax: Dublin 01 4592329 – 24 hours

Post: Otter House

Naas Road

Clondalkin

Dublin 22

Mira Showers

Kohler Mira Ltd
Cromwell Road,
Cheltenham GL52 5EP.

Mira is a registered trade mark of Kohler Mira Limited. The company reserves the right to alter product specifications without notice.



BS EN ISO 9001 : 1994
Reg. No. FM 14648

mira
SHOWERS