

Installation Instructions For Monsoon Extra Standard Single Duty Pump



Medium Pressure S1.4 bar
High Pressure S3.0 bar

High Pressure S3.5 bar
High Pressure S4.5 bar

INDEX	Page No	INDEX	Page No
Application	1	Commissioning	12
Storage	1	Maintenance	14
Typical Installation	2	Technical Specification	15
Pump Location	2	Noise	16
Pipework Connections	4	Trouble Shooting Guide	16
Pump Connections	6	Environment Protection	17
Electrical Installation	9		

PRODUCT DESCRIPTION

Electric motor driven centrifugal pump, complete with an automatic control system, consisting of flow switches and electronic controls.

APPLICATION

The Monsoon Extra Standard Single range is designed for pressure boosting applications in vented stored hot or cold clean water systems where under gravity, some flow is available. Inlet pressures to the pump and ambient temperatures must not exceed the values given in the technical specifications.



- **This pump set must not be used for any other application without the written consent of Stuart Turner Limited and in particular, must not be connected directly to the mains water supply.**
- **This appliance is not intended for use by persons (including children) with reduced physical, sensory or mental capabilities, or lack of experience and knowledge, unless they have been given supervision or instruction concerning use of the appliance by a person responsible for their safety.**
Children should be supervised to ensure that they do not play with the appliance.

STORAGE

If this product is not to be installed immediately on receipt, ensure that it is stored in a dry, frost and vibration free location in its original packaging.

Please leave this instruction booklet with the pump as it contains maintenance and safety information (Original Instructions)

TYPICAL INSTALLATION (Hot Water, Standard Duty, Single Pump System)



The plumbing installation must comply with the following:

The Water Supply (Water Fittings) Regulations 1999. BS6700 and building regulations.

Be installed by a competent person.

- **If in doubt contact Stuart Turner Ltd**

This diagram should be used for schematic reference only

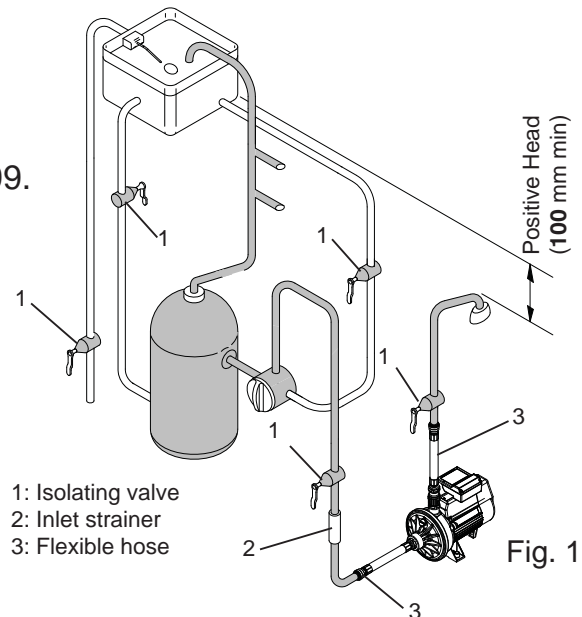

STEP 1 PUMP LOCATION (General)

WARNINGS:



- **The pump must not be located where the inlet pressure to the pump is greater than 10 metres (1 bar).**
- **Pump Location**
If possible site the pump in a location where in the unlikely event of a water leak, any spillage is contained or routed to avoid electrics or areas sensitive to water damage.
- **Care should be taken to protect pump from frost and freezing, particularly when located in a loft installation.**
- **The motor casing can become very hot under normal operating conditions, care should be taken to ensure it cannot be touched during operation.**

The pump must be installed so that the following conditions are met:

Locate the pump in a frost free horizontal position where it cannot be sprayed with water and as close to the water source as possible, having a minimum flooded suction head of 1 metre at all times. Ensure the water flow is in the direction of the arrow that is marked on the flow switch reed clamp (vertically upwards).

For the pump to function correctly, it must be installed in a positive head position, a gravity flow of one litre per minute is required from the highest outlet to operate the built-in flow switch. This is normally achieved with a static head of 100 mm from base of header tank to highest position of the shower terminal fitting.

Before deciding where to position the unit, check to ensure the static inlet head of water above the pump does not exceed the values given in Figs. 2, 3 or 4.

The pump must be installed on its anti-vibration mounting feet and must not be screwed down.

Typical pump locations are in an airing cupboard, or inside a vanity unit with a small purpose built dry and ventilated enclosure. The enclosure should have a minimum clearance of 80 mm (3") between the pump and housing on all sides. The enclosure should be secure and access should only be available by the use of tools.

Hot Water Installations

The preferred pump location is at floor level next to the hot water cylinder or a level that is below the secondary tapping that feeds the pump. This will ensure the pump has access to an air free water supply which is important for trouble free operation (Fig. 2).

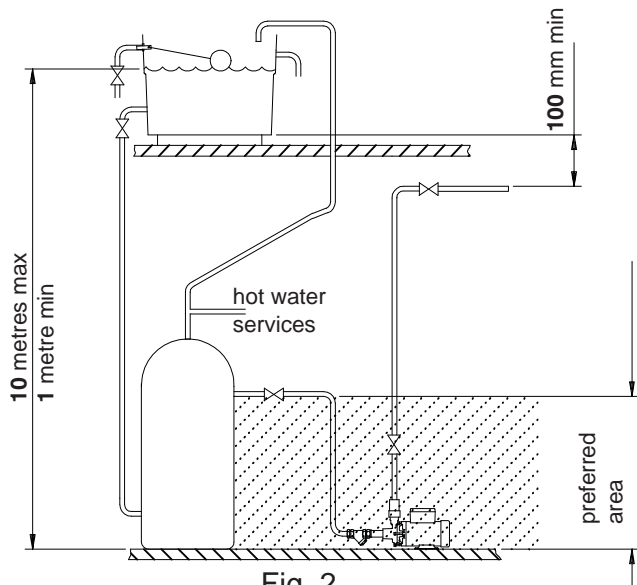

Fig. 2

Preferred Pump Location (shaded area). Pump at a level below draw off tapping in cylinder.

If it is not possible to locate the pump in the preferred area due to site limitations and it is necessary to position the unit in the loft, or in a position above the secondary tapping that feeds the pump, then there is an increased risk of air locks. This risk must be eliminated.

The following measures are suggestions that may overcome the problem:

- 1) A "U" bend or downward loop in the supply pipe to the pump of 350 mm depth before rising to the pump should ensure the cylinder vents its air up the expansion pipe not up the pump feed (Fig. 3).
- 2) An alternative to the above would be the installation of an automatic air vent situated at the top of a vertical pipe run, directly connected to the pump discharge. This will ensure any air collecting in the pump is automatically vented.

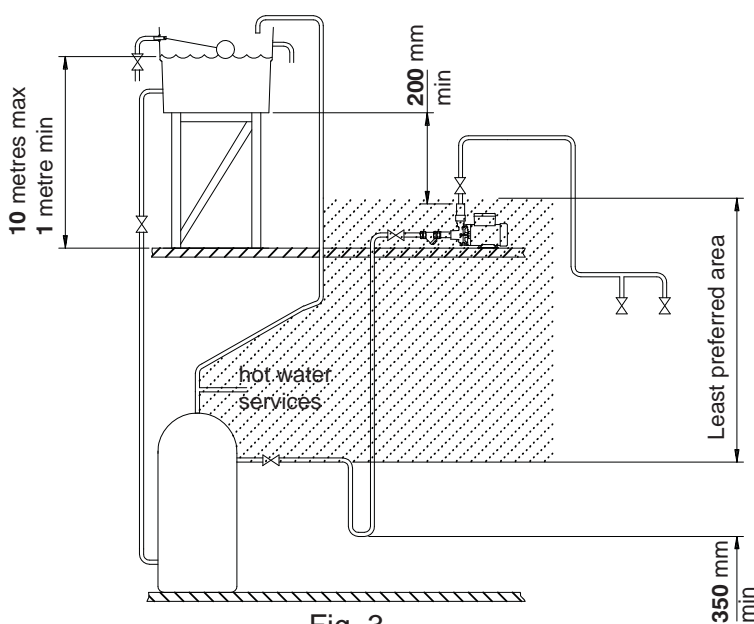

Fig. 3

Note: If installed in loft there must be a height of 200 mm from base of tank to pump.

Least Preferred Pump Location (shaded area). Pump located above the hot cylinder can increase the risk of air locks.

Cold Water Installation

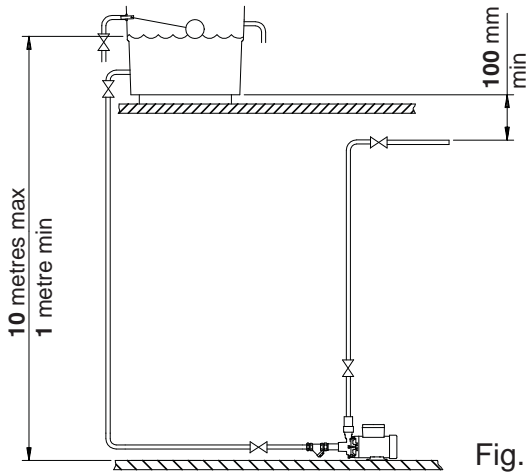

Fig. 4

Diagram showing typical cold water boosting installation.

STEP 2 PIPEWORK CONNECTIONS (General)

WARNINGS:



- Ensure pipework to and from pump is independently supported to prevent forces being transferred to inlet and outlet branches of pump.
- Do not introduce solder flux to pumps or pump parts manufactured from plastic. All solder joints should be completed and flux residues removed prior to pump connection.
- Do not allow contact with oil or cellulose based paints, paint thinners or strippers, acid based descalents or aggressive cleaning agents.
- Always install isolating valves to both suction and delivery pipework.
- **Do not install a non-return valve, or devices which contain non-return valves, in the suction (inlet) pipework to the pump. The pump must be free to vent to the supply tanks at all times.**

It must be ensured that the water storage capacity is sufficient to meet the flow rates required by the pump and any other water using fittings and appliances, which may be operated simultaneously.

As a rule of thumb: assuming a cold water temperature of 10°C and a hot water temperature of 65°C.

- A 6-minute shower using 10 litres/min will consume 40 litres of hot water and 20 litres of cold. This means the total quantity of water used from the cold water storage tank will be 60 litres (40 + 20).
- A 10-minute shower using 15 litres/min will consume 100 litres of hot water and 50 litres of cold. This means the total quantity of water used from the cold water storage tank will be 150 litres (100 + 50).

On installations where there are high flow requirements e.g. multiple showers or body jets.

- A 10-minute shower using 45 litres/min will consume 300 litres of hot water and 150 litres of cold. This means the total quantity of water used from the cold water storage tank will be 450 litres (300 + 150).

The pipework feeds to the storage tank should be of adequate size to ensure replenishment rate of tanks is sufficient to meet needs of pump.

Care should be taken in the design of pipework runs, to minimize the risk of air locks.

To prevent loss of water pressure through pipework use 28 mm suction pipework to the pump minimising 90° bends.

Isolating valves (not supplied) should be fitted on the suction and delivery pipework to enable easy isolation and access to the pump.

The 1" inline strainer as supplied should be fitted in the suction line to the pump between the isolating valve and the pump. This will eliminate the risk of debris or scale entering the pump.

Pipework Connections (Cold)

The pump must be supplied with a dedicated feed direct from the cold water storage tank.

Ensure the pipework size from the cold water storage tank to the pump is of adequate size and a minimum of 28 mm.

The supply must be air free and connections of the feed pipe to the tank should be via a tank connector, positioned at a slightly lower level (25 mm minimum) than the feed pipe to the hot water cylinder.

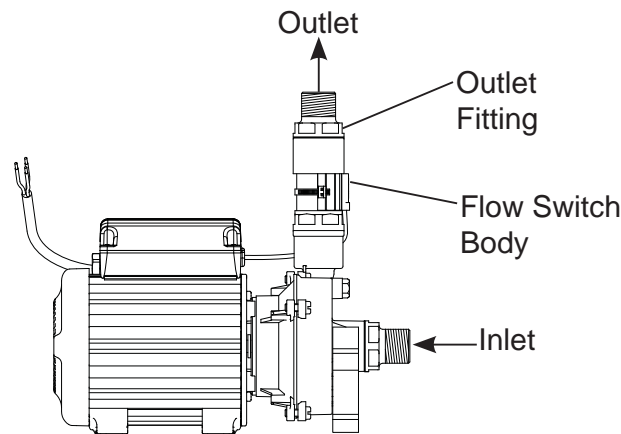

S1.4 bar Single
Fig. 5

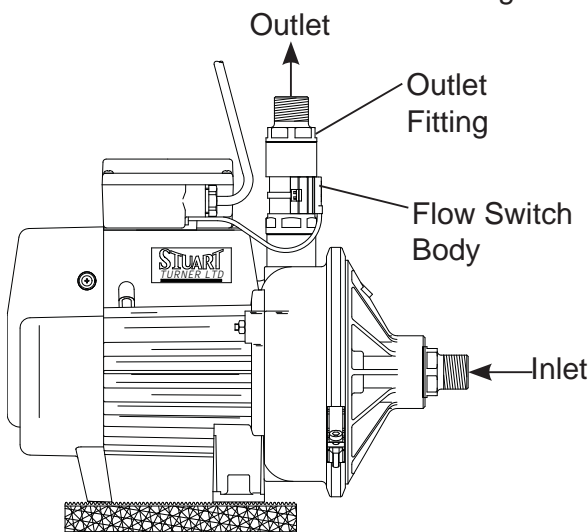

S3.0 and S3.5 bar Single
Fig. 6

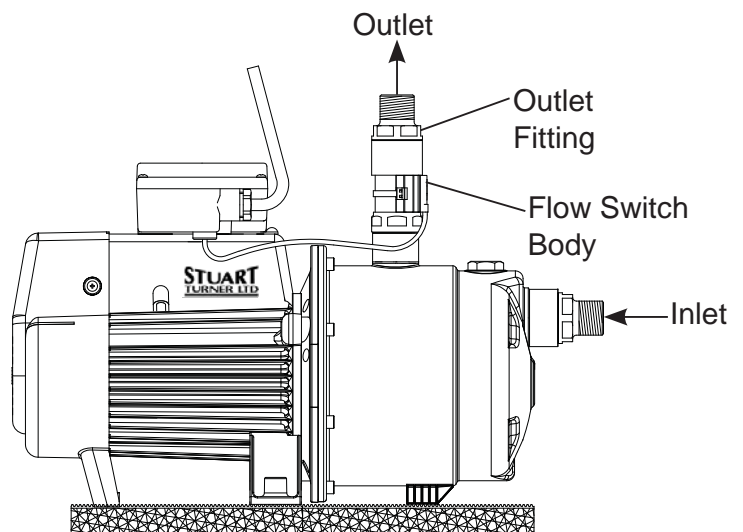

S4.5 bar Single
Fig. 7

Pipework Connections (Hot)

When a hot water cylinder or storage tank is used, ensure the pipework size from the cold water storage to the hot water storage is of adequate size and a minimum of 28 mm.

The pump must be supplied with a dedicated feed direct from the hot water cylinder or storage tank.

Ensure the pipework size from the hot water storage tank to the pump is of adequate size and a minimum of 28 mm. The supply must be air free and connection to the cylinder can be via an Essex flange, or by one of the following methods shown in Fig. 8.

When the method of connection is to be made via the expansion pipe, the cold water cistern should be at least 1.5 metres above the top of the hot water cylinder.

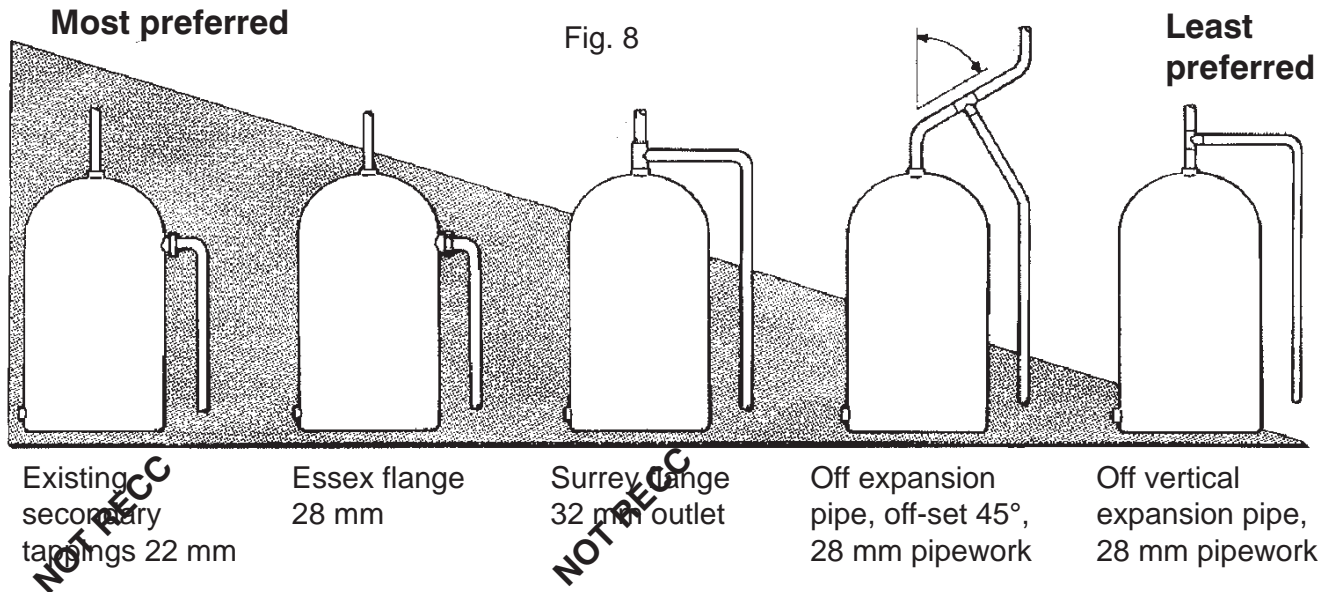

NOTE: Care should be taken in the design of pipework runs, to minimise the risk of air locks in pipework.

Pipework Connections (Connection between pump and shower valves or taps)

This should run as far as possible in 22 mm copper tube. Any bend requirements should be achieved by hand drawing the tube or by use of the appropriate bend fittings. Pipework should only be reduced to 15 mm copper if necessary when entering the terminal fittings. By this method the maximum performance of the pump will be maintained. All pipework should be securely clipped.

STEP 3 PUMP CONNECTIONS (Release And Connection Of Push-in Connectors)

WARNINGS: (Push-in Connectors)



- **Do not use stainless steel, chrome or nickel plated pipe with Stuart Turner push-in plumbing connections.**
- **Do not introduce solder flux into the joint or surrounding area as connectors will be attacked and may fail.**
All solder joints should be completed and flux residues removed before final connection to push-in connections, either on flexible hose or pump head.
- **Do not allow contact with oil or cellulose based paints, paint thinners or strippers, acid based descalents or aggressive cleaning agents.**

Hose to Pump

The pump inlet and outlet ports have factory assembled fittings which are specifically designed for connection to the G³/₄ female running nuts on the flexible hoses. The hose end is fitted with a rubber sealing washer which is held captive within the nut assembly. Locate the hose into position and screw the nut fully onto the fitting by hand. Finally nip tight with a spanner (4/5 Nm) for a water tight seal (**do not overtighten**).

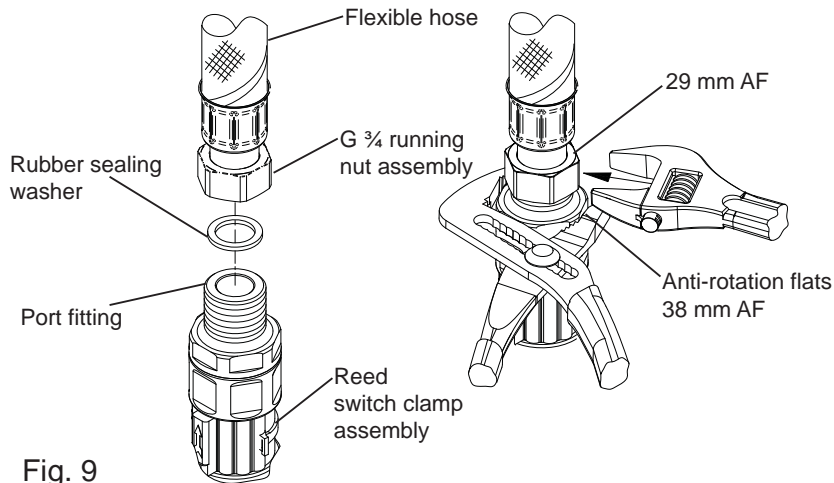

Note: When tightening or loosening the hose nut assembly, the anti-rotation flats provided on the inlet and outlet fittings should be used for placement of a second spanner as shown. This is to prevent complete assembly rotation. It may be necessary to partially rotate the reed switch clamp assembly on the outlet fitting to avoid damage during placement of the second spanner.

Fig. 9

Hose to Pipework

1. Stuart Turner recommend only the use of their 22 mm flexible hoses.

The hoses are fitted with plastic push-in connectors, which must only be connected with the following:

- 22 mm diameter copper pipe to BS EN 1057 - R250 (half hard) - Table 3.
- 22 mm plastic pipe to BS 7291 part 1 and part 2 (Table 1), or part 3 (Table 1) plus internal support sleeve*.

* The internal bore of the plastic pipe must be supported against collapse with the pipe manufacturers recommended support sleeve (pipe insert).

- Appropriate plumbing fittings from the John Guest 'speedfit' push-in plumbing fitting range.

Other manufacturers fittings are not necessarily compatible and may not provide a water tight connection.

Ensure the pipe is free from all score marks and deformities in the area of the insertion depth (Fig. 10) and cut the pipe square removing all burrs and sharp edges to prevent damage to the sealing 'O'-ring.

2. Prior to inserting pipe into fitting mark the insertion depth on the wall of the pipe with a soft pencil at a distance of 35 mm from the end to be inserted (Fig. 10).

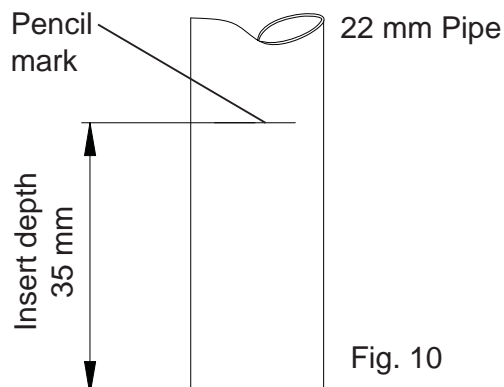
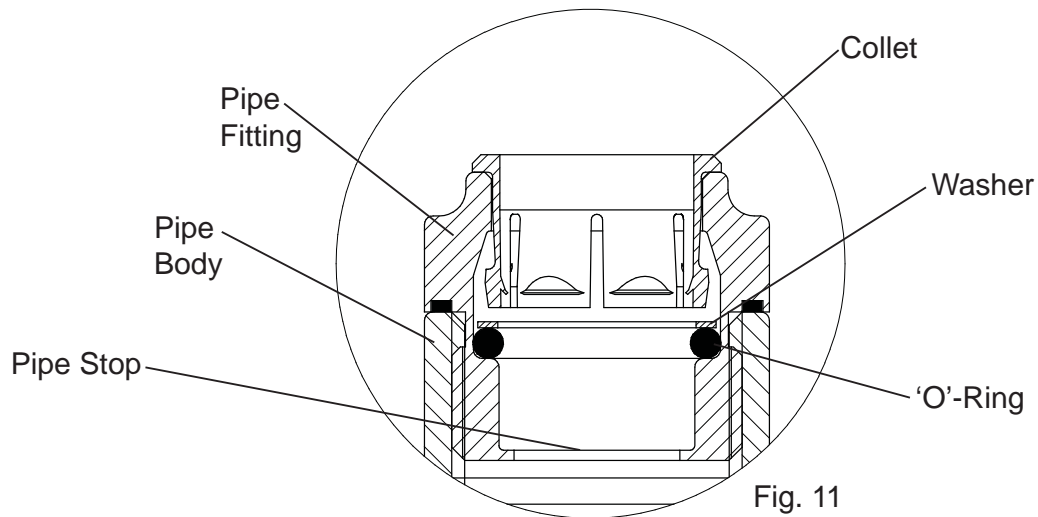

Fig. 10

3. Check in the mouth of the fitting that 'O'-ring, nylon washer and collet are in position.



4. Push pipe firmly into fitting, until pencil mark is level with the top of the collet and the pipe stop resistance is felt. Pull on pipe to check it is secure and correctly fitted.
5. To release the joint, push pipe firmly into fitting, hold the collet down and gently remove pipe. If the system has been filled with water, care should be taken to isolate pump and towels used to absorb spilled water.

If you have any concern either about using push-in fittings or should the joint leak on final test isolate the water supplies and contact Pump Assist on 0844 98 000 97.

Pump Connections (General)

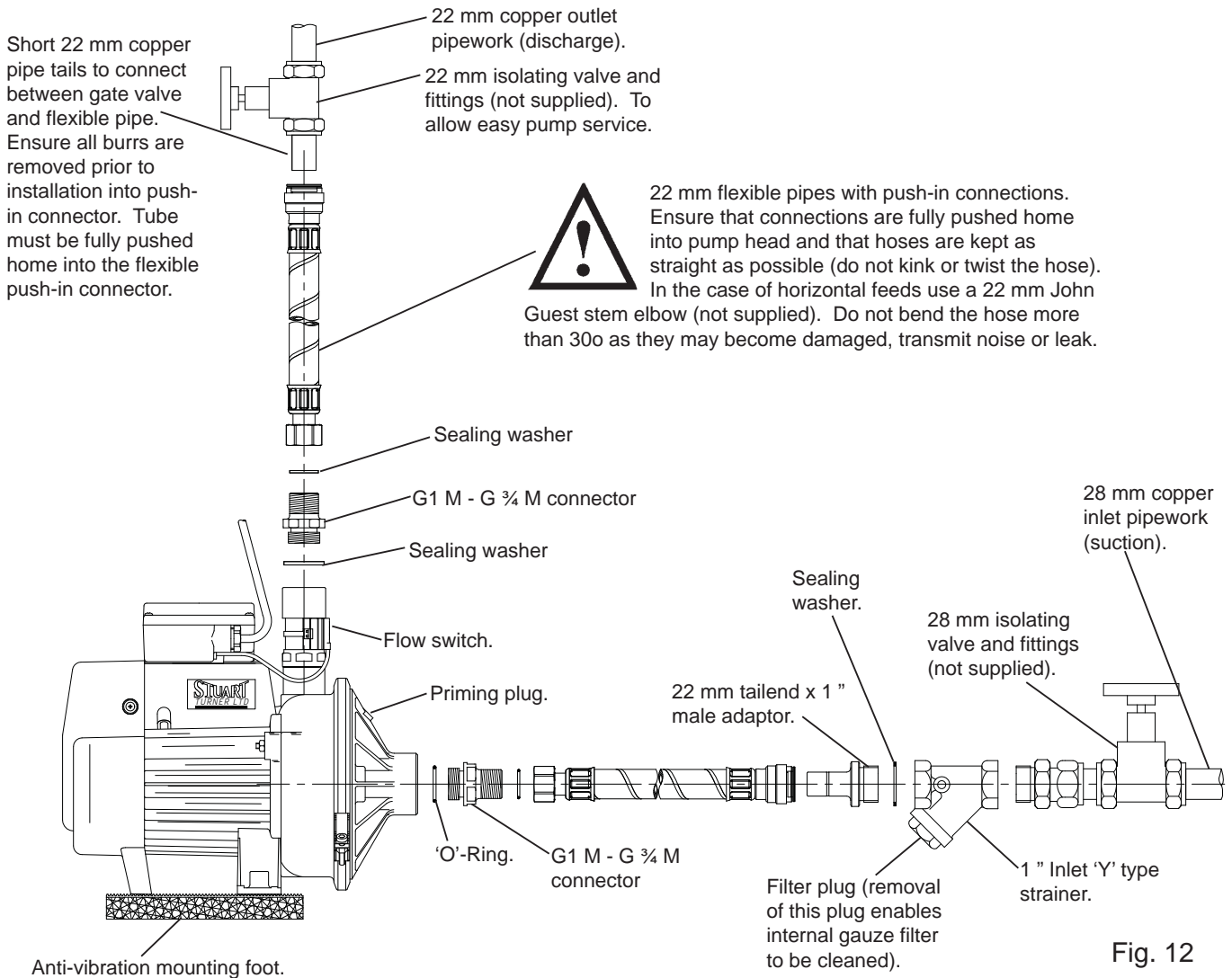

Fig. 12

The pump should not be screwed down, ensure anti-vibration feet and flexible hoses are used.

STEP 4 ELECTRICAL INSTALLATION

WARNINGS:



- The electrical installation must be carried out in accordance with the current national electrical regulations and installed by a competent person.
- In the interests of electrical safety a 30 mA residual current device (R.C.D.) should be installed in the supply circuit. This may be part of a consumer unit or a separate unit.
- The motor and wiring must not be exposed to water.
- Before starting work on the electrical supply ensure power supply is isolated.
- Do not allow the supply cord to contact hot surfaces, including the motor shell, pump body or pipework. The cord should be safely routed and secured by cable clips.

Cont ...

The motor fitted to this pump is suitable for a 230/1/50Hz supply. It is thermally protected by an integral auto resetting thermotrip for your safety and rated for the duty listed in the technical specification section.

Electrical Connection

The motor is provided with a factory fitted supply cord. This must be permanently connected to the fixed wiring of the mains supply. Means for disconnection must be incorporated in the fixed wiring in accordance with the wiring rules.

A suitable method of connection would be via a double pole switched, fused connection unit complying with BS 1363-4, protected with a fuse (see fuse section).

The connection unit should be mounted in an easily accessible position and should be labelled if confusion is possible, to allow easy identification of the pump isolating switch.

Earthing

This appliance must be earthed via the supply cord, which must be correctly connected to the earth point located in the terminal box.

Copper or metallic pipework must have supplementary earth bonding where the continuity has been broken by flexible hoses or plastic components. Adjacent suction and delivery pipes should be fitted with earthing clamps to BS 951 and connected with earthing wire size 4 mm² (Fig. 13).

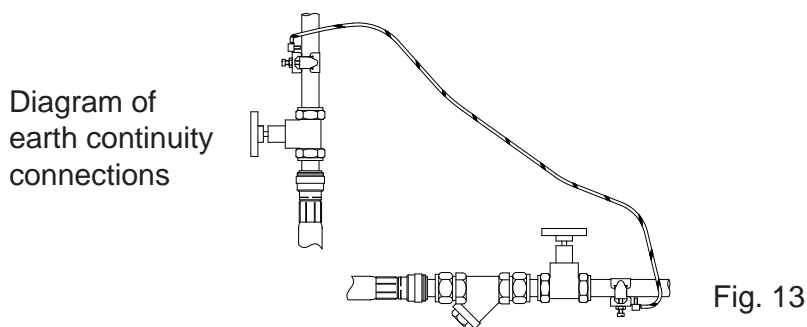

Certain installations may require additional earthing arrangements such as equipotential bonding. Reference should be made to the relevant regulations concerning this subject to ensure compliance.

Wiring Of Connection Unit



WARNING: This appliance must be earthed.

The wires in the mains lead are coloured in accordance with the following code:

Green and Yellow: Earth Blue: Neutral Brown: Live

As the colours of the wires in the mains lead of this appliance may not correspond with the coloured markings identifying the terminals in your connection unit proceed as follows:

The wire which is coloured green and yellow must be connected to the terminal in the connection unit which is marked with the letter E or by the earth symbol:  or coloured green or green and yellow.

The wire which is coloured blue must be connected to the terminal which is marked with the letter N or coloured black.

The wire which is coloured brown must be connected to the terminal which is marked with the letter L or coloured red.

Wiring Diagrams



- **Parallel wiring of two single pumps is not recommended.**
- **The supply cord and internal wiring within the terminal box are routed and secured to ensure compliance with the electrical standard EN 60335-1. It is essential that any disturbance of this internal wiring is avoided and the factory routing and securing of all internal wiring is always maintained.**

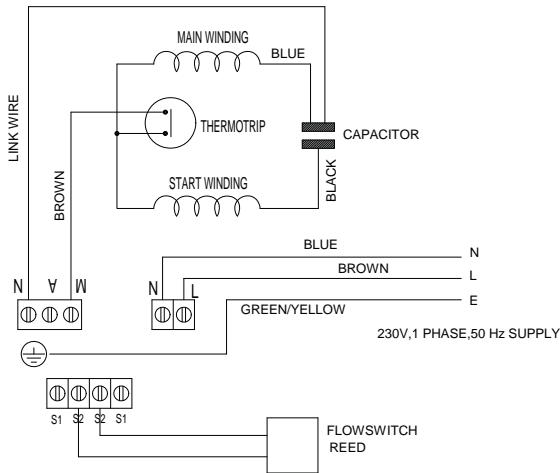

Monsoon Extra S1.4 bar Single
Fig. 14

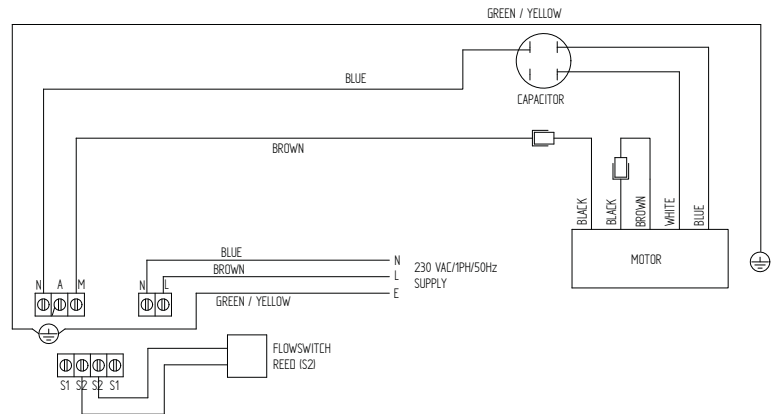

Monsoon Extra S3.0, S3.5 and S4.5 bar Single
Fig. 15

Fuses

The following fuse size should be used with the appropriate pump:

Model	Fuse Size (AMPS)
Monsoon Extra S1.4 bar	5
All Other Models	13

Supply Cord Replacement

If the supply cord is to be changed or is damaged, it must be replaced with a special cord assembly available from Stuart Turner or one of their approved repairers.

On disassembly note the cord retention and routing system. Reassemble to the same pattern.

For information on cable connection consult the wiring diagram and cable gland fitting instructions.

Intermediate Connecting Cord Replacement (Monsoon S3.0, S3.5 and S4.5 models only)

These pumps incorporate an additional cord which connects the main terminal box to the motor terminal box. If this cord is damaged, it must be replaced with a special cord assembly available from Stuart Turner or one of their approved repairers.

On disassembly note the cord retention and routing system. Re-assemble to the same pattern.

For information on cable connection consult the wiring diagram.

Cont ...

Supply Cord Extension

The pumps are fitted with a supply cord to the following specification:-

Monsoon S1.4 bar:- HO5VV-F3 G 0.75 mm² - 6 Amp rated cable.

Monsoon S3.0, S3.5 and S4.5 bar:- . . . HO7RN-F3 G 1.0 mm² - 10 Amp rated cable.

If the supply cord is to be extended, a cord of the same specification should be used. Any connections or junction boxes used should be specifically suited for the application and installed in accordance with the manufacturers instructions.

Cable Gland Fitting Instructions

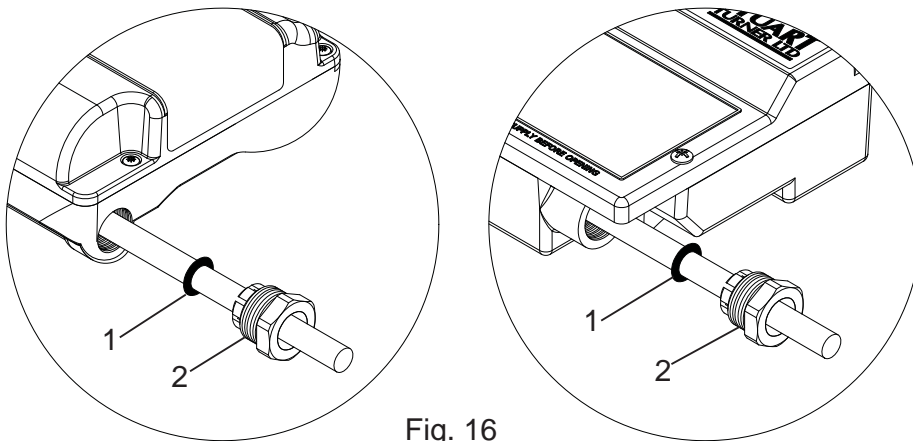

Fig. 16

To enable correct assembly of the cable gland the 'O'-ring (1) must be placed over the cable before the clamping insert (2) can be tightened.

Note: Cable diameter range:- 6.5 mm to 9.5 mm.

STEP 5 COMMISSIONING

WARNINGS:



- **The motor casing can become very hot under normal operating conditions, care should be taken to ensure it cannot be touched during operation.**
- **Do not run pump without guards and terminal box lid correctly fitted.**
- **The pump chamber must be full of water at all times. Seal damage will result if the pump runs dry.**



1. System Flushing

This pump incorporates push-in connectors and plastic components that must not come into contact with solder flux, acid-based descalents or aggressive cleaning agents. The pipework system should be flushed out prior to the pump being connected to ensure any contaminants/chemical residues and foreign bodies are removed from elsewhere in the system.



2. Water Supply

Always ensure that water storage capacity is adequate to meet the demand. Ensure the pump chamber is full of water before starting the pump. Failure to do this could result in seal damage. To ensure dry running does not occur the pump must be primed as described in the priming section. **Do not run pump dry.**

Cont ...

3. Priming

The pump must be primed (filled with water) before starting. Turn on water supply, prime and vent the pump by unscrewing the priming plug (Figs. 17, 18 & 19) slowly until all air escapes and water emerges. Re-tighten the plug.

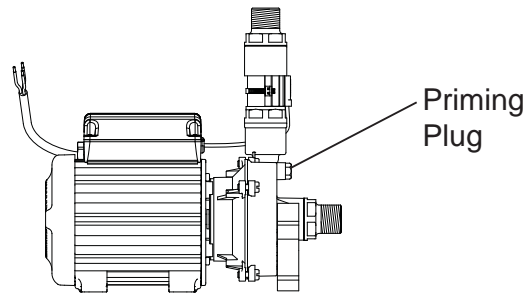

S1.4 bar Single
Fig. 17

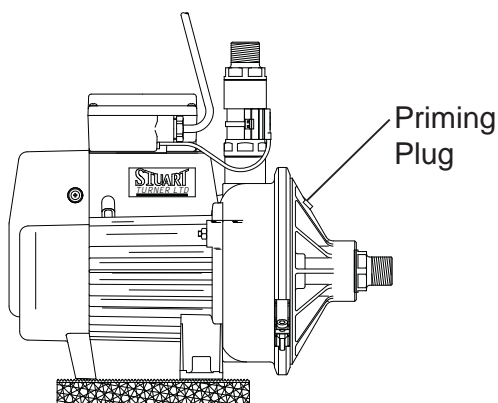

S3.0 and S3.5 bar Single
Fig. 18

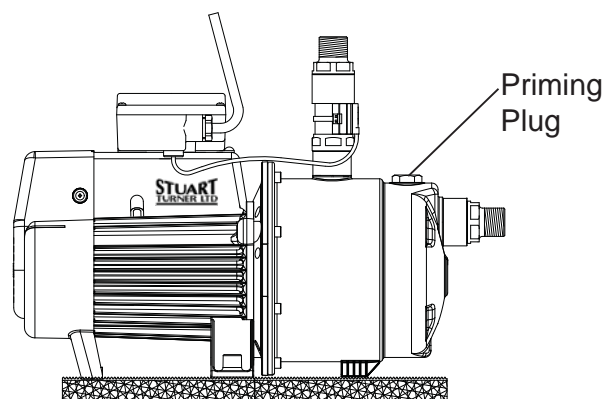

S4.5 bar Single
Fig. 19

4. Pre-Start Check

Always ensure the pump is in a positive head position with flooded suction. A gravity flow of one litre/min from the highest outlet is required to operate the integral flow switch.

5. Starting

- a) Switch on power and open terminal fitting. Pump should start and stop upon demand.
- b) Open and close all outlets in turn associated with the pump, (including w/c systems) allowing water to flow from each outlet until all air is purged. As each outlet is opened and closed, the pump will start and stop respectively.
- c) Any tap or control valve within the system when opened and closed will now turn the pump on/off. Check system for leaks, if clear the system is now operating correctly.
- d) Carefully check pump and pipework for leaks whilst pump running and stationary before leaving the installation unattended.

For Further Technical Support

Phone the Stuart Turner Pump Assist team on 0844 98 000 97. Our staff are trained to help and advise you over the phone or arrange for a service engineer to call.

Cont ...

MAINTENANCE

WARNINGS:



- Care should be taken to protect pump from frost and freezing, particularly when located in a loft installation.
- Pump Location

If possible site the pump in a location where in the unlikely event of a water leak, any spillage is contained or routed to avoid electrics or areas sensitive to water damage.



1. No routine maintenance is required but provision should be made for easy access to the pump to allow for repairs due to normal wear and tear.
2. Disconnect electrical supply before working on pump.
3. Turn off water supplies to the pump and release pressure by opening water outlets before attempting maintenance.
4. The inlet strainer incorporates a removable gauze filter which may require periodical cleaning. The frequency of this operation is dependent upon installation conditions. The strainer is located in the inlet pipework to the pump (see page 8). The gauze filter is removed as follows:-
 - a) Isolate pump electrically.
 - b) Release all system pressure.
 - c) Isolate water supply.
 - d) Remove screwed hexagonal plug from strainer body (see page 8).
 - e) Remove and clean stainless steel gauze filter.
 - f) Reassemble gauze and secure plug tightly.
 - g) Turn on water supplies, connect power supply and test.
5. As water is heated scale deposits are released in areas of hard water (usually south of a line between the Wash and Bristol Channel), scale can cause the mechanical seal to stick if left without use for long periods. We recommend the pump is run for at least 5 minutes every four weeks to “exercise” all working parts. Run on cool water. See technical specification for note on water temperature. This particularly applies to guest bathrooms used infrequently.

Cleaners, Disinfectants and Descalents



On installations where chemical disinfectants or descalents are periodically used, the compatibility of the chemical solution regarding the pump must be considered.

Acid based descalents and aggressive cleaning agents must not come into contact with the pump. The pump must be removed from the system prior to the use of these products. The system should be flushed to remove all chemicals before the pump is re-connected.

If in any doubt as to the suitability of the chemical solutions, please contact our Pump Assist helpline.

TECHNICAL SPECIFICATION

Model		S1.4 bar	S3.0 bar	S3.5 bar	S4.5 bar
Electrical	Power supply Volts/phase frequency	230/1/50	230/1/50	230/1/50	230/1/50
	Enclosure	IPX4	IPX4	IPX4	IPX4
	Type of motor	Induction	Induction	Induction	Induction
	Power consumption	445 Watts	880 Watts	1135 Watts	1060 Watts
	Full load current	2.0 Amps	3.9 Amps	5.2 Amps	4.9 Amps
	Rating	Continuous (S1)	Continuous (S1)	Continuous (S1)	Continuous (S1)
	Max. No Starts per hour	60	60	60	60
Mechanical	Max inlet head	10 metres	10 metres	10 metres	10 metres
	Max head (closed valve)	14 metres	31 metres	32 metres	47 metres
	Max working pressure*	500kPa (5.0 bar)	400 kPa (4.0 bar)	430 kPa (4.3 bar)	600 kPa (6.0 bar)
	Max ambient air temperature	40 °C	40 °C	40 °C	40 °C
	Max water temperature**	65 °C	65 °C	65 °C	65 °C
	Min water temperature	4 °C	4 °C	4 °C	4 °C
Dimensions	Length	260 mm	344 mm	368 mm	443 mm
	Width	133 mm	210 mm	210 mm	202 mm
	Height (excluding flexible hoses)	249 mm	299 mm	299 mm	301 mm
	Gross Weight (packed)	6.9 Kg	11.1 Kg	12.5 Kg	13.3 Kg

Stuart Turner reserve the right to amend the specification in line with its policy of continuous development of its products.

Note: For information on other voltages/frequencies which are not shown, consult any supplementary instruction sheet supplied, or the rating label attached to the pump.

***Note:** Max working pressure is the maximum pressure that can be applied to the pump internal casing under any installation conditions.

****Note:** In normal circumstances the temperature of stored water should never exceed 65°C. A stored water temperature of 60°C is considered sufficient to meet all normal requirements and will minimise deposition of scale in hard water areas.



Maximum permissible water temperature 65°C.

Cont ...

NOISE

The equivalent continuous A-weighted sound pressure level at a distance of 1 metre from the pump does not exceed 70 dB(A).

TROUBLE SHOOTING GUIDE

Symptoms	Probable Cause	Recommended Action
Pump will not start.	No water. Water supply. Filter blocked. Electrical supply. Faulty reed switch/PCB. Integral auto resetting thermotrip activated.	Check gravity flow of water is available to the fittings of at least 1 l/min. If NO... check water level in the supply tank and all stopcocks are open. Remove and clean system filters. Check wiring connections. Check all switches are 'on'. Check correct fuse fitted. Check circuit breaker is set. Refer to circuit test as detailed in Fig. 20. Allow to cool and investigate cause of problem before restarting.
No hot water (if applicable).	Air locked. Water feed. Boiler is switched off. Faulty thermostatic mixer valve.	Vent hot water pump of air. Check cold feed to hot water cylinder. Check water level in cold water tank and that all stopcocks are open. Check boiler is switched 'on'. Check cylinder thermostat. Check immersion heater. Check cylinder contains hot water. Consult makers instructions.
Pump starts when outlets are off.	Leak in system.	Check tap washers, ball valve washers, pipe joints.
Pump runs on when all terminal outlets are closed.	Leak in system. Reed clamp out of position. Jammed flow switch. Faulty reed switch or P.C.B.	Check tap washers, w/c valve washers, pipe joints. Ensure reed clamp is fitted correctly in location groove (Fig. 20). Remove flow switch reed clamp whilst pump is running, if pump stops proceed to isolate the pump electrically and hydraulically and remove brass housing that contains float. Check for free movement. Remove flow switch reed clamp whilst pump is running. If pump continues to run, this indicates a closed circuit in either the flow switch reed or P.C.B. in the terminal box, these should be checked electrically.
Reduced flow/performance.	Blocked inlet strainers.	Clean inlet strainers (see maintenance section).

Cont ...

Flow Switch Circuit Test

1. First confirm visually that the flow switch reed clamp have not been dislodged during handling or installation. The clamp must be fully located within the flow switch body groove as shown.
2. To carry out the following test you will need to obtain a magnet, a typical fridge magnet is suitable.
3. Ensure the power supply is switched on.
4. Position the magnet directly in front of the reed clamp as shown. If pump does not start, then slowly move the magnet up and down to a position that exceeds the extent of the reed clamp. The pump should instantaneously start at some point during this extent of movement. If this does not happen, this indicates a possible fault with the reed switch or the P.C.B which is located within the terminal box. These should be checked electrically. Consult Stuart Turner for further instructions.

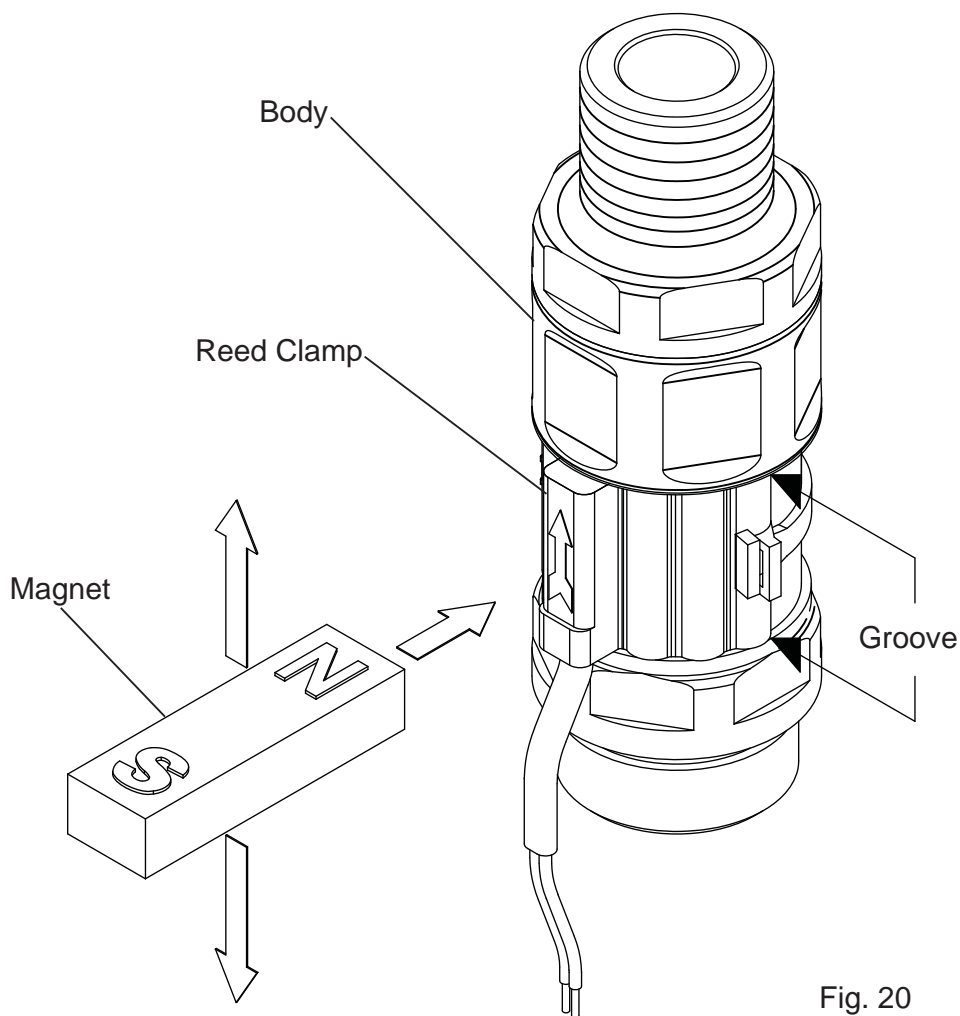

Fig. 20

ENVIRONMENT PROTECTION

Your appliance contains valuable materials which can be recovered or recycled.

At the end of the products' useful life, please leave it at an appropriate local civic waste collection point.

GOOD PRACTICE

Always flush system prior to installing a new or serviced pump.

Always ensure the pump is primed (filled with water) before starting. **DO NOT RUN PUMP DRY.**

Always ensure the pump has a minimum flooded suction head of 1 metre at all times.

Always ensure anti-vibration feet are used.

Ensure pump is sited in dry ventilated position.

Do not allow pump to freeze.

Abide by the Water Supply (Water Fittings) Regulations 1999.

Always install isolating gate valve to both suction and delivery pipework.

Ensure earth continuity between suction and delivery pipes.

Always ensure pump wiring conforms with the current national electrical regulations and is installed by a competent person.

Do not install a non-return valve, or devices which contain non-return valves, in the suction (inlet) pipework to the pump. The pump must be free to vent to the supply tanks at all times.

Disconnect electrical supply before working on pump or motor.

Carefully check pump and pipework for leaks before leaving the installation unattended.

YOUR 2 YEAR GUARANTEE

Stuart Pumps are guaranteed by Stuart Turner Limited to be free from defects in materials or workmanship for the applicable guarantee period from the date of purchase. The applicable guarantee period is stated in the installation booklet supplied with the pump. Within the guarantee period we will repair, free of charge, any defects in the pump resulting from faults in material or workmanship, repairing, exchanging parts or exchanging the whole unit as we may reasonably decide.

Not covered by this guarantee: Damage arising from incorrect installation, improper use, unauthorised repair, normal wear and tear and defects which have a negligible effect on the value or operation of the pump.

Reasonable evidence must be supplied that the pump has been purchased within the applicable guarantee period prior to the date of claim (such as proof of purchase or the pump serial number).

This guarantee is in addition to your statutory rights as a consumer. If you are in any doubt as to these rights, please contact your local Trading Standards Department or Citizen's Advice Bureau.

In the event of a claim please telephone Stuart Turner Limited on 0844 980 0097 or return your pump and flexible hoses with accessories removed, plugs, pipes etc. If you have any doubt about removing a pump, please consult a professional.

Proof of purchase should accompany the returned pump to avoid delay in investigation and dealing with your claim.

Please record here for your records.

TYPE NO.	SERIAL NO.	DATE PURCHASED



DECLARATION OF CONFORMITY

2006/42/EC

BS EN ISO 12100-1, BS EN ISO 12100-2, BS EN 809

2006/95/EC

BS EN 60335-1, BS EN 60335-2-41, EN 50366

2004/108/EC

BS EN 55014-1, BS EN 55014-2, BS EN 55022, BS EN 61000-3-2, BS EN 61000-3-3,
BS EN 61000-4-2, BS EN 61000-4-3, BS EN 61000-4-4, BS EN 61000-4-5, BS EN 61000-4-6,
BS EN 61000-4-11

IT IS HEREBY CERTIFIED THAT THE STUART ELECTRIC MOTOR DRIVEN PUMP AS
SERIAL NUMBER BELOW, COMPLIES WITH THE ESSENTIAL REQUIREMENTS OF THE
ABOVE E.E.C. DIRECTIVES.

(_____)

RESPONSIBLE PERSON
AND MANUFACTURER

STUART TURNER LIMITED
HENLEY-ON-THAMES, OXFORDSHIRE
RG9 2AD ENGLAND.

Signed.....

Customer Relationship Manager

Stuart Turner are an approved company to BS EN ISO 9001:2000

**STUART
TURNER**

Stuart Turner Ltd, Henley-on-Thames, Oxfordshire RG9 2AD ENGLAND

Tel: +44 (0) 1491 572655, Fax: +44 (0) 1491 573704

email: pumps@stuart-turner.co.uk web: www.stuart-turner.co.uk

V.A.T. REG. No. 199 0987 92. Registered in England No. 88368. Registered Office: Market Place, Henley-on-Thames